

Agilent 81570A, 71A, 76A, 77A & 78A
Variable Optical Attenuators

User's Guide

Notices

This document contains proprietary information that is protected by copyright. All rights are reserved.

No part of this document may be reproduced in (including electronic storage and retrieval or translation into a foreign language) without prior agreement and written consent from Agilent Technologies Deutschland GmbH as governed by United States and international copyright laws.

© Copyright 2001 - 2004 by:
Agilent Technologies Deutschland GmbH
Herrenberger Str. 130
71034 Böblingen
Germany

Subject Matter

The material in this document is subject to change without notice.

Agilent Technologies makes no warranty of any kind with regard to this printed material, including, but not limited to, the implied warranties of merchantability and fitness for a particular purpose.

Agilent Technologies shall not be liable for errors contained herein or for incidental or consequential damages in connection with the furnishing, performance, or use of this material.

Printing History

New editions are complete revisions of the guide reflecting alterations in the functionality of the instrument. Updates are occasionally made to the guide between editions. The date on the title page changes when an updated guide is published. To find out the current revision of the guide, or to purchase an updated guide, contact your Agilent Technologies representative.

Control Serial Number: First Edition applies directly to all instruments.

Warranty

This Agilent Technologies instrument product is warranted against defects in material and workmanship for a period of one year from date of shipment. During the warranty period, Agilent will, at its option, either repair or replace products that prove to be defective.

For warranty service or repair, this product must be returned to a service facility designated by Agilent. Buyer shall prepay shipping charges to Agilent and Agilent shall pay shipping charges to return the product to Buyer. However, Buyer shall pay all shipping charges, duties, and taxes for products returned to Agilent from another country.

Agilent warrants that its software and firmware designated by Agilent for use with an instrument will execute its programming instructions when properly installed on that instrument. Agilent does not warrant that the operation of the instrument, software, or firmware will be uninterrupted or error free.

Limitation of Warranty

The foregoing warranty shall not apply to defects resulting from improper or inadequate maintenance by Buyer, Buyer-supplied software or interfacing, unauthorized modification or misuse, operation outside of the environmental specifications for the product, or improper site preparation or maintenance.

No other warranty is expressed or implied. Agilent Technologies specifically disclaims the implied warranties of Merchantability and Fitness for a Particular Purpose.

Exclusive Remedies

The remedies provided herein are Buyer's sole and exclusive remedies. Agilent Technologies shall not be liable for any direct, indirect, special, incidental, or consequential damages whether based on contract, tort, or any other legal theory.

Assistance

Product maintenance agreements and other customer assistance agreements are available for Agilent Technologies products. For any assistance contact your nearest Agilent Technologies Sales and Service Office.

Certification

Agilent Technologies Inc. certifies that this product met its published specifications at the time of shipment from the factory.

Agilent Technologies further certifies that its calibration measurements are traceable to the United States National Institute of Standards and Technology, NIST (formerly the United States National Bureau of Standards, NBS) to the extent allowed by the Institutes' calibration facility, and to the calibration facilities of other International Standards Organization members.

ISO 9001:2000 Certification

Produced to ISO 9001:2000 international quality system standard as part of our objective of continually increasing customer satisfaction through improved process control.

Manual Part Number

81570-90A01

Eighth Edition:
81570-90A01: September 01, 2005

Seventh Edition:
81570-90A01: July 20, 2005

Sixth Edition:
81570-90A01: December, 2004

Fifth Edition:
81570-90A01: June 28, 2004

Fourth Edition:
81570-90A01: January 31, 2003

Third Edition:
81560-90A13: October 29, 2002

Second Edition:
81560-90A12: August 04, 2002

First Edition:
81560-90A11: November 2001

Safety Summary

The following general safety precautions must be observed during all phases of operation, service, and repair of this instrument. Failure to comply with these precautions or with specific warnings elsewhere in this manual violates safety standards of design, manufacture, and intended use of the instrument. Agilent Technologies Inc. assumes no liability for the customer's failure to comply with these requirements.

Before operation, review the instrument and manual, including the red safety page, for safety markings and instructions. You must follow these to ensure safe operation and to maintain the instrument in safe condition.

WARNING

The WARNING sign denotes a hazard. It calls attention to a procedure, practice or the like, which, if not correctly performed or adhered to, could result in injury or loss of life. Do not proceed beyond a WARNING sign until the indicated conditions are fully understood and met.

CAUTION

Optical power levels above 100 mW applied to single mode connectors can easily damage the connector if it is not perfectly clean. Also, scratched or poorly cleaned connectors can destroy optical connectors mechanically. Always make sure that your optical connectors are properly cleaned and unscratched before connection. Refer to chapter "Cleaning Information" on page 77 on appropriate procedures for connector cleaning and inspection. However, Agilent Technologies Deutschland GmbH assumes no responsibility in case of an operation that is not compliance with the safety instructions as stated above.



Safety Symbols

The apparatus will be marked with this symbol when it is necessary for the user to refer to the instruction manual in order to protect the apparatus against damage.



Hazardous laser radiation.

Initial Inspection

Inspect the shipping container for damage. If there is damage to the container or cushioning, keep them until you have checked the contents of the shipment for completeness and verified the instrument both mechanically and electrically.

The Performance Tests give procedures for checking the operation of the instrument. If the contents are incomplete, mechanical damage or defect is apparent, or if an instrument does not pass the operator's checks, notify the nearest Agilent Technologies Sales/Service Office.

WARNING

To avoid hazardous electrical shock, do not perform electrical tests when there are signs of shipping damage to any portion of the outer enclosure (covers, panels, etc.).

WARNING

You *MUST* return instruments with malfunctioning laser modules to an Agilent Technologies Sales/Service Center for repair and calibration.

Line Power Requirements

The Agilent 81570A, 71A, 78A Variable Optical Attenuator modules and Agilent 81576A, 77A Variable Optical Attenuator modules with Power Control operate when installed in the Agilent 8163A and B Lightwave Multimeters, the Agilent 8164A and B Lightwave Measurement Systems, or the Agilent 8166A and B Lightwave Multichannel Systems.

Within this User's Guide, these instruments are collectively referred to as 'mainframes'.

Operating Environment

The safety information in your mainframe's User's Guide summarizes the operating ranges for the Agilent 81570A, 71A, 78A Variable Optical Attenuator modules and Agilent 81576A, 77A Variable Optical Attenuator modules with Power Control. In order for these modules to meet specifications, the operating environment must be within the limits specified for your mainframe.

Storage and Shipment

Agilent 81570A, 71A, 78A Variable Optical Attenuator modules and Agilent 81576A, 77A Variable Optical Attenuator modules with Power Control can be stored or shipped at temperatures between

-40°C and +70°C.

Protect the module from temperature extremes that may cause condensation within it.

Environmental Information

This product complies with the WEEE Directive (2002/96/EC) marking requirements. The affixed label indicates that you must not discard this electrical/ electronic product in domestic household waste.

Product Category: With reference to the equipment types in the WEEE Directive Annex I, this product is classed as a "Monitoring and Control instrumentation" product.

Do not dispose in domestic household waste.

To return unwanted products, contact your local Agilent office, or see www.agilent.com/environment/product/ for more information.



Firmware Prerequisites

For Agilent 8156x modules with a particular firmware revision to operate correctly, your Agilent 8163A/B, 8164A/B, or 8166A/B mainframe must have a V3.5, or later, firmware revision installed.

For Agilent 8157x modules with a particular firmware revision to operate correctly, your Agilent 8163A/B, 8164A/B, or 8166A/B mainframe must have a V4.0, or later, firmware revision installed.

Firmware files are provided on the OCT Support CD-ROM supplied with the instrument, and the latest firmware revisions can also be downloaded via www.agilent.com/comms/octfirmware

The firmware for A and B versions of our mainframes is not binary compatible. Make sure you select the appropriate firmware for your instrument.

- NOTE
- Updating mainframe firmware does not require you to update the firmware in every hosted module. New revisions of mainframe firmware are backwards compatible with older module firmware.
 - You may find it advantageous to update module firmware. To help you determine which module firmware to update, a readme file is provided with the firmware file detailing its revision history.
 - If the serial number of your 8164A Lightwave Measurement System is DExxxx339 or below, problems with writing files to the floppy disk drive may occur in rare cases. If this is the case, please contact your nearest Agilent Technologies Sales / Service Office.

Checking your Current Firmware Revision

8163A/B Lightwave Multimeter, 8164A/B Lightwave Measurement System, or 8166A/B Lightwave Multichannel System

To check your 8163A/B Lightwave Multimeter, 8164A/B Lightwave Measurement System, or 8166A/B Lightwave Multichannel System's firmware revision:

- 1** Press the Config hardkey.
- 2** Move to the <About Mainframe> menu option and press Enter.
- 3** The manufacturer, part number, instrument number, and firmware revision are listed. If the firmware revision number is less than V3.5 for 8156x modules, or is less than V4.0 for 8157x modules, follow the Update Procedure described in the readme.txt in the root directory of the OCT Support CD-ROM supplied with the instrument to install a later firmware revision.

8157x Series Modules

To check an 8157x series, module's firmware revision:

- 1** Press the Config hardkey.
- 2** Move to the <About Modules> menu option and press Enter. You see a box displaying the slots that have a module installed.
- 3** Move to the appropriate slot using the cursor key and press Enter.
- 4** The part number, module number, and firmware revision of the chosen module are displayed. If the firmware revision number is less than V4.0 for 8157x modules, follow the Update Procedure described in the readme.txt in the root directory of the OCT Support CD-ROM supplied with the instrument to install a later firmware revision.

The Structure of this Manual

This manual is divided into two parts:

- Getting Started
This section gives an introduction to the attenuator modules and aims to make these modules familiar to you:
 - “*Getting Started with Attenuator Modules*” on page 15.
- Additional Information
This is supporting information of a non-operational nature, concerning accessories, specifications, and performance tests:
 - “*Accessories*” on page 25,
 - “*Specifications*” on page 31, and
 - “*Performance Tests*” on page 47.

Conventions used in this manual

- Hardkeys are indicated by italics, for example, *Config*, or *Channel*.
- Softkeys are indicated by normal text enclosed in square brackets, for example, [Zoom] or [Cancel].
- Parameters are indicated by italics enclosed by square brackets, for example, [*Range Mode*], or [*MinMax Mode*].
- Menu items are indicated by italics enclosed in brackets, for example, <*MinMax*>, or <*Continuous*>.

Table of Contents

Safety Summary	3
Safety Symbols	3
Initial Inspection	3
Line Power Requirements	4
Operating Environment	4
Storage and Shipment	4
Firmware Prerequisites	4
Checking your Current Firmware Revision	6
8163A/B Lightwave Multimeter, 8164A/B Lightwave Measurement System, or 8166A/B Lightwave Multichannel System	6
8157x Series Modules	6
The Structure of this Manual	7
Conventions used in this manual	7
Getting Started with Attenuator Modules	15
<hr/>	
What is an Attenuator?	17
Installation	17
Variable Optical Attenuator Front Panels	18
Front Panel Controls and Indicators	19
Typical Use Models	21
Optical Output	23
Angled and Straight Contact Connectors	23
Accessories	25
<hr/>	
Modules and Options	27
Modules	28
User's Guides	28
Connector Interfaces and Other Accessories	29
Specifications	31
<hr/>	
Definition of Terms	33
Attenuation	34
Attenuation flatness	34
Attenuation range	35

Attenuation setting mode	35
Attenuation uncertainty	35
Constant operating conditions	35
Insertion loss	36
Insertion loss flatness	36
Maximum Input Power	36
Operating temperature	37
Polarization Dependent Loss (PDL)	37
Polarization Extinction Ratio(PER)	37
Power setting mode	37
Relative power meter uncertainty	37
Repeatability (of attenuation or total loss)	38
Resolution	38
Return Loss	38
Settling Time	39
Shutter Isolation	39
Spectral ripple	39
Total loss	40
Transition speed	40
Wavelength Range	40
Specifications	41
Performance Tests	47
<hr/>	
Required Test Equipment	48
Performance Test Procedure	50
Insertion Loss Test	51
Accuracy test	53
Repeatability Test	54
Power Setting Repeatability Test	54
Wavelength Flatness Test (Not applicable to 81578A)	55
Return Loss Test (Not applicable to 81578A)	56
Polarization Dependent Loss (PDL) Test - Scanning Method (Not applicable to 81578A)	57
Polarization Dependent Loss (PDL) Test - Mueller Method (Not applicable to 81578A)	59

Cleaning Information	77
Safety Precautions	79
Why is it important to clean optical devices?	80
What materials do I need for proper cleaning?	80
Standard Cleaning Equipment	80
Dust and shutter caps	81
Isopropyl alcohol	81
Cotton swabs	81
Soft tissues	82
Pipe cleaner	82
Compressed air	82
Additional Cleaning Equipment	83
Microscope with a magnification range about 50X up to 300X	83
Ultrasonic bath	83
Warm water and liquid soap	84
Premoistened cleaning wipes	84
Polymer film	84
Infrared Sensor Card	84
Preserving Connectors	85
Cleaning Instrument Housings	85
General Cleaning Procedure	86
How to clean connectors	86
How to clean optical head adapters	87
How to clean connector interfaces	88
How to clean bare fiber adapters	89
How to clean lenses and instruments with an optical glass plate	89
How to clean instruments with a fixed connector interface	90
How to clean instruments with a physical contact interface	90
How to clean instruments with a recessed lens interface	92
How to clean optical devices which are sensitive to mechanical stress and pressure	92
How to clean metal filters or attenuator gratings	93
Additional Cleaning Information	94
How to clean bare fiber ends	94
How to clean large area lenses and mirrors	94
Other Cleaning Hints	96

List of Figures

Figure 1	Agilent 81576A/77A Optical Attenuators with Power Control	7
Figure 2	Agilent 81570A Attenuator with Straight Connector	8
Figure 3	Agilent 81571A Attenuator with Angled Connector	8
Figure 4	Agilent 81578A Multimode Attenuator with Straight Connector.	9
Figure 5	Agilent 81576A High-power Attenuator with Power Control and Straight Connector	10
Figure 6	Agilent 81577A High-power Attenuator with Power Control and Angled Connector	10
Figure 7	Angled and Straight Contact Connector Symbols	13
Figure 8	Mainframes, Variable Optical Attenuator Modules, and Options.	17
Figure 9	Insertion Loss Reference	40
Figure 10	Insertion Loss Test	41
Figure 11	Return Loss Reference Setup for SM attenuators	45
Figure 12	Return Loss Test Setup for SM attenuators	45
Figure 13	PDL Test Setup - Scanning Method for SM attenuators	47
Figure 14	PDL Reference Setup for SM attenuators.	49
Figure 15	PDL Test Setup - Mueller method	51
Figure 16	Relative Power Meter uncertainty Setup for SM attenuators	53



Getting Started with Attenuator Modules

This chapter describes the:

- Agilent 81570A, 81571A VOA modules,
- Agilent 81578A Multimode VOA and the
- Agilent 81576A and 81577A VOA modules with power control

CAUTION

Optical power levels above 100 mW applied to single mode connectors can easily damage the connector if it is not perfectly clean. Also, scratched or poorly cleaned connectors can destroy optical connectors mechanically. Always make sure that your optical connectors are properly cleaned and unscratched before connection. Refer to chapter "Cleaning Information" on page 77 on appropriate procedures for connector cleaning and inspection. However, Agilent Technologies Deutschland GmbH assumes no responsibility in case of an operation that is not compliance with the safety instructions as stated above.

What is an Attenuator?

Agilent 8157x Variable Optical Attenuators attenuate and control the optical power of light in single and multimode optical fibers. They allow you to set the attenuation factor and/or power level manually, or via the host instrument's GPIB interface.

Agilent 81576A and 81577A attenuators include power control functionality that allows you to set the output power level of the attenuator. When power control mode is enabled, the module automatically corrects for power changes at the input so that the output power level set by the user is maintained. See Figure 1 on page 17.

Installation

Agilent 8157xA Variable Optical Attenuators are front-loadable modules for the Agilent 8163A/B Lightwave Multimeter, 8164A/B Lightwave Measurement System, and 8166A/B Lightwave Multichannel System, collectively referred to as 'mainframes'.

An Agilent 81570A, 71A or 78A module occupies one slot, while an Agilent 81576A or 77A module occupies two slots.

For a description of how to install your module, refer to "How to Fit and Remove Modules" in the Installation and Maintenance chapter of your mainframe's User's Guide.

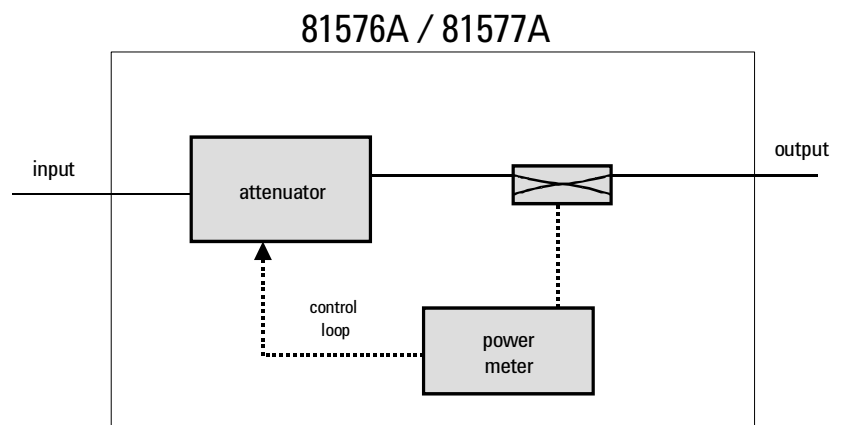

Figure 1 Agilent 81576A/77A Optical Attenuators with Power Control

Variable Optical Attenuator Front Panels

Agilent 81570A

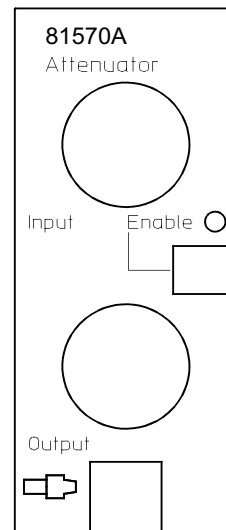

Figure 2 Agilent 81570A Attenuator with Straight Connector

Agilent 81571A

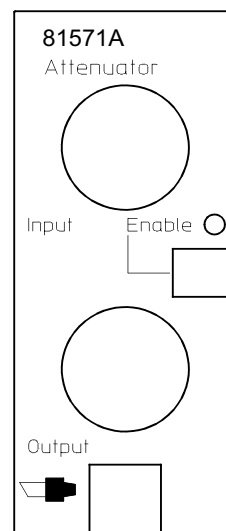

Figure 3 Agilent 81571A Attenuator with Angled Connector

Agilent 81578A

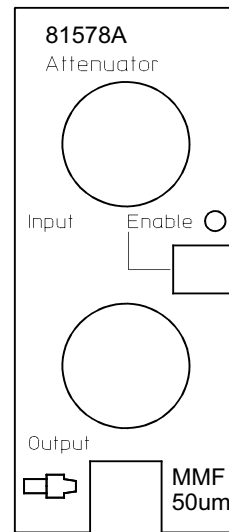

Figure 4 Agilent 81578A Multimode Attenuator with Straight Connector

Agilent 81576A

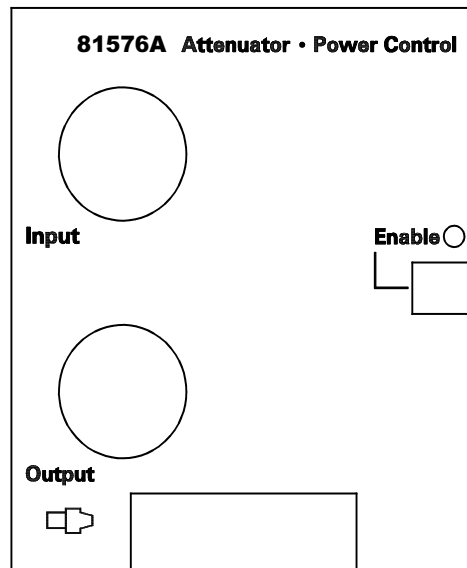

Figure 5 Agilent 81576A High-power Attenuator with Power Control and Straight Connector

Agilent 81577A

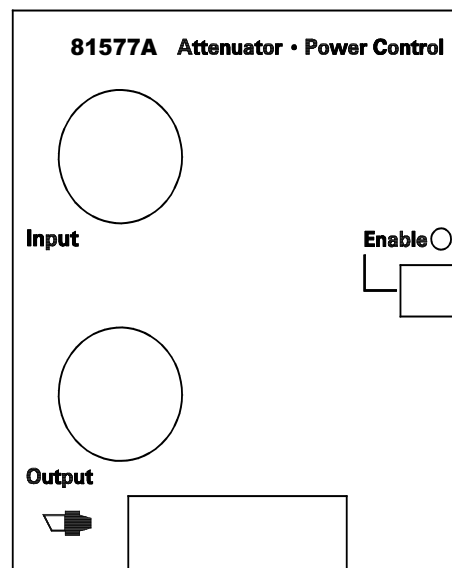

Figure 6 Agilent 81577A High-power Attenuator with Power Control and Angled Connector

Front Panel Controls and Indicators

The front panel contains a push button to switch the shutter open/closed, and a LED that indicates the state of the shutter. If the shutter is “open”, the LED shows “enable”, and light can pass through the instrument.

Typical Use Models

Brief description	Agilent's 8157xA Variable Optical Attenuators are instruments that attenuate and control the optical power level of light in single and multimode optical fibers. As plug-in modules for Agilent's Lightwave Multichannel platform (8163A/B, 8164A/B, 8166A/B) they allow you to set the attenuation factor and/or power level manually, or remotely via a common computer interface. Their high accuracy combined with their flexibility make them ideal as test and measurement equipment for the modern telecommunication industry.
Modular Design for Multichannel Platform	Agilent's 8157xA variable optical attenuators are a family of plug-in modules for Agilent's Lightwave Multichannel Platform 8163A/B, 8164A/B and 8166A/B. The attenuator modules 81570A, 81571A, 81578A occupy one slot, while modules 81576A and 81577A occupy two slots. The Agilent 8166A/B Lightwave Multichannel System with its 17 slots can host up to 17 single slot modules (such as the 81570A attenuators) or up to 8 dual slot modules, (such as the 81577A attenuators).
Variable Optical Attenuators	<p>Agilent's 81570A, 81571A and 81578A are small and cost effective attenuator modules with high resolution for single-wavelength applications. Once you have entered the operating wavelength, the instrument automatically applies the appropriate corrections. Various calibration features allow you to set a reference power so that both the attenuation and the power level, relative to the reference power, can be set and displayed in the user interface. An integrated shutter can be used for protection purposes or to simulate channel drops.</p> <p>Agilent's 81570A and 81571A have excellent wavelength flatness and can handle high input power levels. These features, combined with low insertion loss, allow you to use these modules for characterizing EDFAs and Raman amplifiers, as well for other multi-wavelength applications such as DWDM transmission system testing. They include the reference power functionality and an integrated shutter.</p> <p>Agilent's 81578A modular attenuators are available for multimode applications with fiber interface option for 50μm (#050) and 62.5μm (#062).</p>
Attenuators with Power Control	<p>Agilent's 81576A and 81577A attenuators have the power control functionality combined with the high-power handling capability and excellent wavelength flatness required for DWDM applications.</p> <p>To set the the total power level of a multi-wavelength signal, it is necessary to determine the convolution of the signal's spectrum against the sensitivity of the photodiode over wavelength. An enhanced calibration feature allows you to set the integrated power of the DWDM signal against a known spectrum.</p>

Calibration Processes Comprehensive offset functionality in the firmware enhances the calibration of the optical path in various test set-ups. There is an offset for the attenuation factor, and an independent offset for the output power level, to calibrate for losses due to the patch cords and connectors. Additionally, wavelength and offset value pairs can be stored in a table to compensate for wavelength dependent effects in the optical path of the set-up. This allows you to set the optical power level at your Device Under Test.

Calibration is even easier and more convenient if the reference powermeter and the attenuator are hosted by the same mainframe: All power related offsets can be determined by a firmware function that reads a value from the reference powermeter. The difference between the power value read by the reference powermeter and the actual value of the attenuator is automatically stored as the offset.

Optical Output

Angled and Straight Contact Connectors

Agilent 81570A Variable Optical Attenuator modules and 81576A Variable Optical Attenuator modules with Power Control are designed for straight connector interfaces.

Agilent 81571A Variable Optical Attenuator modules and 81577A Variable Optical Attenuator modules with Power Control are designed for angled connector interfaces.

The Agilent 81578A (with option 050 or 062) Variable Optical Attenuator modules are designed for straight (FC/PC) multimode connector.

The inclusion of an angled contact connector is not optionable, and depends on the module part number.

Angled contact connectors help you to control return loss, since reflected light tends to reflect into the cladding, reducing the amount of light that reflects back to the source.

CAUTION

If the contact connector on your instrument is angled, you can only use cables with angled connectors with the instrument.



Figure 7 Angled and Straight Contact Connector Symbols

Figure 7 shows the symbols that tell you whether the contact connector of your attenuator module is angled or straight. The angled contact connector symbol is colored green.

You should connect straight contact fiber end connectors with neutral sleeves to straight contact connectors, or connect angled contact fiber end connectors with green sleeves to angled contact connectors.

NOTE You cannot connect angled non-contact fiber end connectors with orange sleeves directly to the instrument.

See *"Accessories"* on page 25 for further details on connector interfaces and accessories.



Accessories

Agilent 8157xA Variable Optical Attenuator modules are available in various configurations for the best possible match to the most common applications.

This chapter describes the options and accessories available for the:

- Agilent 81570A, 81571A VOA modules,
- Agilent 81578A VOA modules for multimode applications; and the
- Agilent 81576A and 81576A VOA modules with power control.

Modules and Options

Figure 8 shows all the options that are available for Agilent 8157xA Variable Optical Attenuator modules, and the instruments that support these modules.

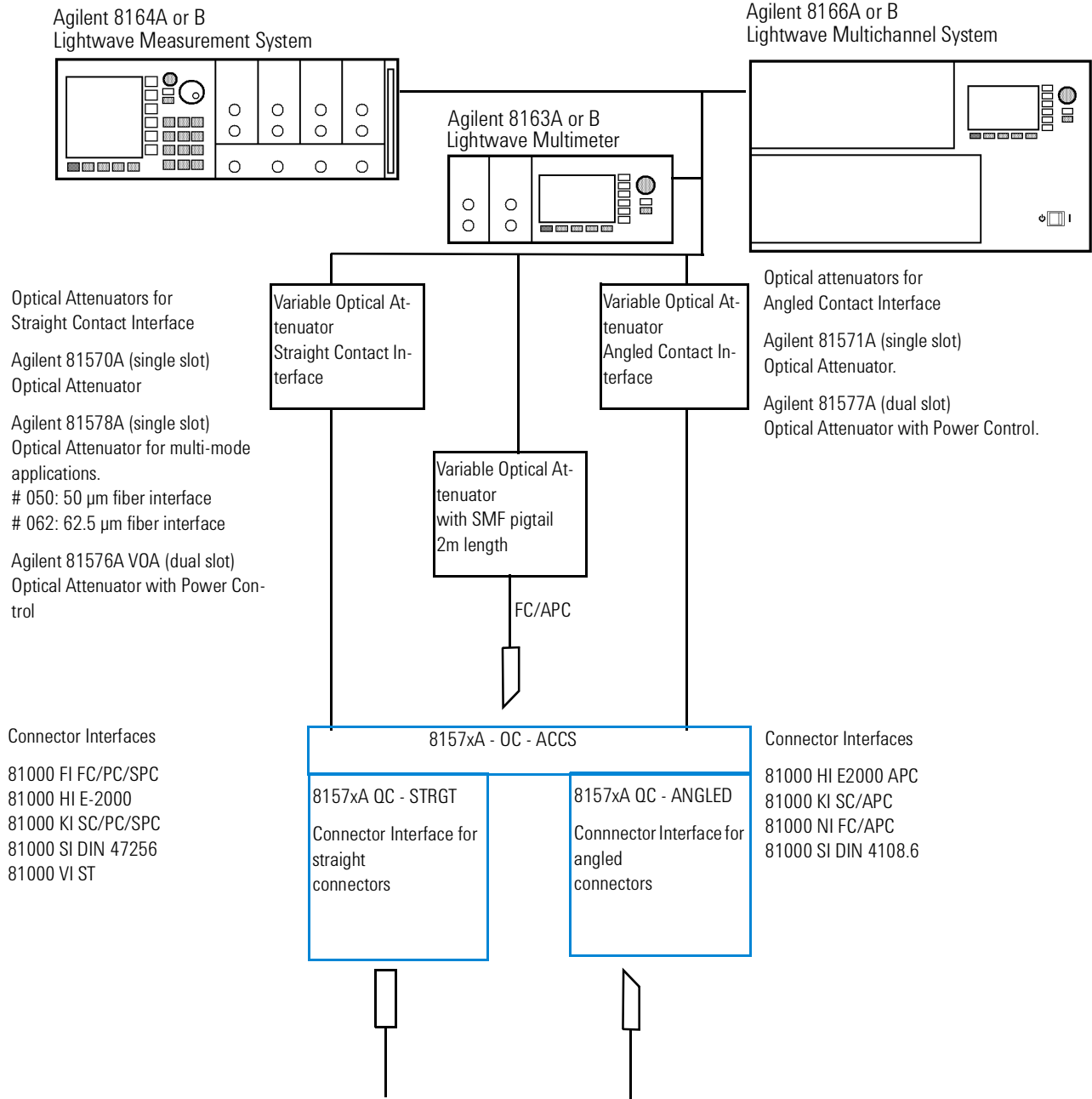

Figure 8 Mainframes, Variable Optical Attenuator Modules, and Options

Modules

Agilent 8157xA Modular Attenuator can be hosted by:

- Agilent 8163A and Agilent 8163B Lightwave Multimeters,
- Agilent 8164A and Agilent 8164B Lightwave Measurement Systems,
- Agilent 8166A and Agilent 8166B Lightwave Multichannel Systems.

User's Guides

User's Guides	
Description	Part No.
Agilent 8157xA Modular Attenuator User's Guide (English).	81570-90A01
Agilent 8163A/B Lightwave Multimeter, Agilent 8164A/B Lightwave Measurement System, & Agilent 8166A/B Lightwave Multichannel System User's Guide.	08164-90B14
Agilent 8163A/B Lightwave Multimeter, Agilent 8164A/B Lightwave Measurement System, & Agilent 8166A/B Lightwave Multichannel System Programming Guide.	08164-90B63

Connector Interfaces and Other Accessories

CAUTION

Optical power levels above 100 mW applied to single mode connectors can easily damage the connector if it is not perfectly clean. Also, scratched or poorly cleaned connectors can destroy optical connectors mechanically. Always make sure that your optical connectors are properly cleaned and unscratched before connection. Refer to chapter "Cleaning Information" on page 77 on appropriate procedures for connector cleaning and inspection. However, Agilent Technologies Deutschland GmbH assumes no responsibility in case of an operation that is not comply with the safety instructions as stated above.

- 81570A, 81578A and 81576A
Variable Optical Attenuator Modules
- If you want to use straight connectors (such as FC/PC, DIN, SC or ST) to connect to the instrument, you must do the following:
- 1 Attach your connector interface to the interface adapter.
See Figure 8 for a list of the available connector interfaces.
 - 2 Connect your cable.
- 81571A and 81577A
Variable Optical Attenuator Modules
- If you want to use angled connectors (such as FC/APC or SC/APC) to connect to the instrument, you must do the following:
- 1 Attach your connector interface to the interface adapter.
See Figure 8 for a list of the available connector interfaces.
 - 2 Connect your cable.



Specifications

Agilent 81570A, 81571A VOA modules for high-power applications, Agilent 81578A VOA for multimode applications and Agilent 81576A and 81577A VOA modules with power control for high-power applications, are all produced to the ISO 9001 international quality system standard as part of Agilent Technologies' commitment to continually increasing customer satisfaction through improved quality control.

Specification: describes a guaranteed product performance that is valid under the specified conditions. Specifications are based on a coverage factor of 2 (unless otherwise stated), corresponding to a level of confidence of >95.4%.

Typical value: a characteristic describing the product performance that is usually met but that is not guaranteed.

Generally, all specifications apply after warm-up, for the stated operating conditions and measurement settings, with the attenuator set to the source wavelength, for transmission from input port to output port, after settling, at uninterrupted line voltage.

Because of the modular nature of the instrument, these performance specifications apply to these modules rather than the mainframe unit.

CAUTION

Optical power levels above 100 mW applied to single mode connectors can easily damage the connector if it is not perfectly clean. Also, scratched or poorly cleaned connectors can destroy optical connectors mechanically. Always make sure that your optical connectors are properly cleaned and unscratched before connection. Refer to chapter "Cleaning Information" on page 77 on appropriate procedures for connector cleaning and inspection. However, Agilent Technologies Deutschland GmbH assumes no responsibility in case of an operation that is not compliance with the safety instructions as stated above.

Definition of Terms

This section defines terms that are used both in this chapter and "*Performance Tests*" on page 47.

Measurement principles are indicated. Alternative measurement principles of equal value are also acceptable.

Attenuation

Difference (in dB) between *total loss* (with any attenuation setting) and *insertion loss* (i.e. with attenuation set to zero) of the attenuator.

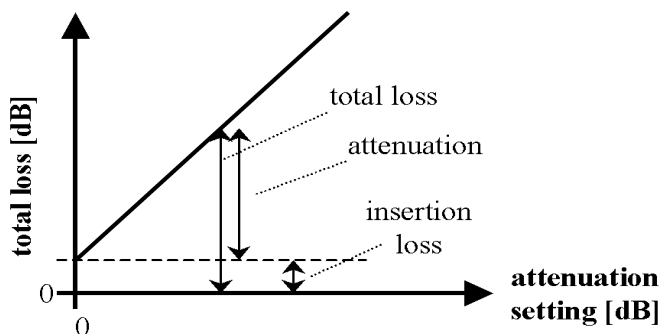

Attenuation flatness

The change of the *Attenuation* over wavelength at any arbitrary but fixed displayed attenuation and fixed wavelength setting of the attenuator. The attenuation flatness is \pm half the maximum span over wavelength, expressed in dB.

Attenuation flatness does not include *Spectral ripple*.

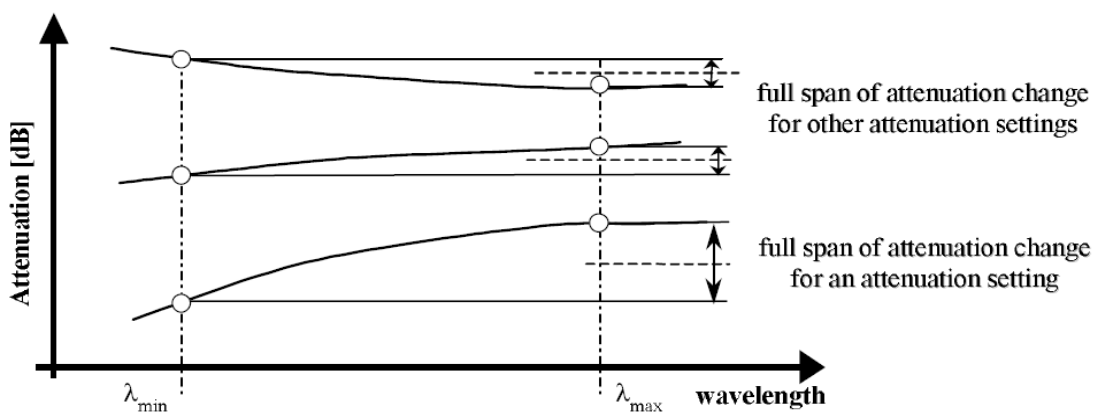

Conditions: Wavelength setting as specified. Temperature range, input polarization as specified. Constant operating conditions. Other conditions as specified.

Measurement: With tunable laser source, polarization scrambler (if applicable), and optical power meter.

NOTE Attenuation flatness does not include *insertion loss flatness* per definition.

Measurement: With an Erbium-Doped Fiber Amplifier to apply the necessary input power, tunable laser source, and optical power meter to probe the wavelength dependence of the attenuation drift.

Attenuation range

Attenuation range that can be set at the attenuator and for which the specifications apply (if not differently stated).

Attenuation setting mode

Operating mode where the user sets the desired attenuation. The power control function (if available) is deactivated in this mode (see also *power setting mode*).

NOTE This operating mode is applicable to attenuators with power control only.

Attenuation uncertainty

The maximum possible difference (in dB) between the displayed *Attenuation* and actual *Attenuation*.

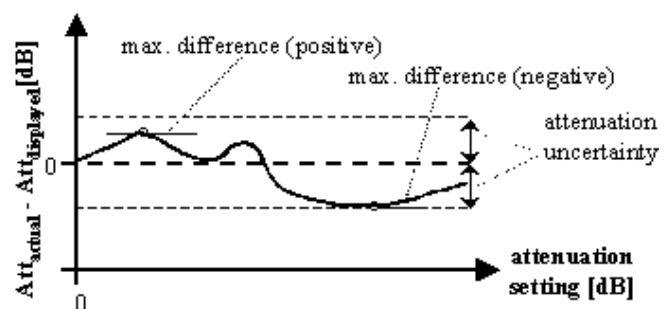

Conditions: Attenuator set to the wavelength of the source. Input polarization, temperature range, maximum power and input mode (multimode attenuators only) as specified. Other conditions as specified.

Measurement: With Fabry-Pérot laser source of applicable wavelength, polarization scrambler (if applicable), and optical power meter.

NOTE When using a polarized source, the attenuation uncertainty increases by \pm half the specified polarization dependent loss of the attenuator (if specified).

Constant operating conditions

This generally includes constant values of temperature, humidity, wavelength, input power level, polarization state and mode distribution (for multimode attenuators), if the quantity is not explicitly subject to variation.

Insertion loss

Specifies the *Total loss* at a displayed attenuation of 0 dB

Conditions: Temperature range, wavelength range, source polarization input polarization, input mode (multimode attenuators only) as specified.

Measurement: With Fabry-Pérot Laser Source, polarization controller (if applicable) and power meter, using high quality connectors in perfect optical condition.

NOTE Insertion loss includes the loss of one additional connector pair.

Insertion loss flatness

The change of the *insertion loss* over wavelength. The insertion loss flatness is \pm half the span between the maximum and minimum insertion loss, expressed in dB. Insertion Loss flatness does not include *spectral ripple*.

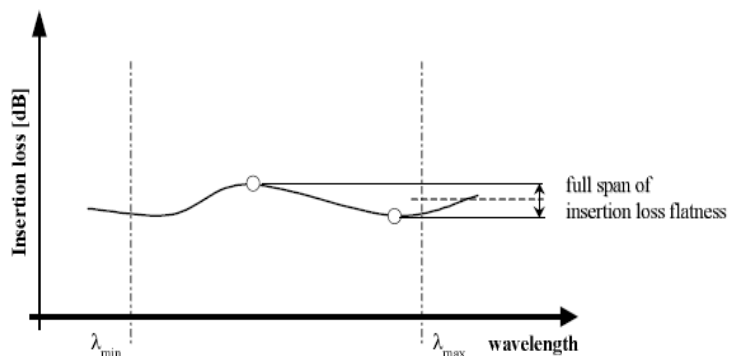

Conditions: Constant operating conditions. Fixed wavelength setting of attenuator. Input polarization, input mode (multimode attenuators only) as specified and constant. Excluding wavelengths of water absorption lines.

Measurement: With tunable laser source, polarization scrambler (if applicable), power meter, using high quality connectors in perfect optical condition. Attenuator set to 0 dB.

Maximum Input Power

The maximum input power level that can be applied to the attenuator without permanent change to its characteristics.

NOTE For input powers > 20 dBm, clean connectors in good condition are vital to avoid thermally induced fiber damage.

Operating temperature

The range of ambient temperatures of the mainframe hosting the attenuator module for which the specifications apply.

Polarization Dependent Loss (PDL)

The dependence of the *total loss* on the input polarization state, expressed as the full difference (in dB) between the highest and the lowest total loss.

Conditions: Temperature range, input mode (multimode attenuators only) as specified.

Measurement: Using high quality connectors in perfect optical condition.

NOTE PDL is a peak-to-peak value.

Polarization Extinction Ratio(PER)

The ratio of optical power in the slow axis of the polarization maintaining fiber to the optical power in the fast axis.

Conditions: Input power level; temperature, humidity constant; other conditions as in the Specifications; polarized light with TE mode injected in the slow axis of the polarization maintaining fiber of the attenuator.

Measurement: with ASE source and crossed-polarizer method.

Power setting mode

Operating mode where the user sets the desired output power. The power control function of the attenuator automatically adjusts the attenuation to get the set output power (see also *attenuation setting mode*).

NOTE This operating mode is applicable to attenuators with power control only.

Relative power meter uncertainty

When changing the output power of the attenuator, the relative power meter uncertainty is the maximum error of the displayed output power ratio to the actual output power ratio. This uncertainty is caused by the internal power meter's nonlinearity and noise and by errors in the sensing hardware, expressed as \pm half the span of all possible errors with an offset due to the noise level of the power meter. Symbol *RU*.

Conditions: Reference power level 1mW, wavelength and polarization state constant; power limitations as in the Specifications; zeroing prior to measurement.

Measurement: The nonlinearity is calculated using the displayed power ratio $D2 / D1$ and the corresponding actual power ratio $P2 / P1$:

$$N_{dB}(1,2) = 10 \cdot \log\left(\frac{D_2 / D_1}{P_2 / P_1}\right)$$

The relative power meter uncertainty is then calculated using:

$$RU_{dB} = \pm \frac{\max |N_{dB}(1,2)|}{2}$$

RU is then expressed in dB and the offset is expressed in pW.

NOTE This operating mode is applicable to attenuators with power control only.

NOTE Absolute power accuracy attainable with the help of an external optical power meter.

Repeatability (of attenuation or total loss)

Specifies the uncertainty in reproducing the *total loss* (or *attenuation*) after randomly changing and re-setting the attenuation. The repeatability is defined as $\pm 2 \times \text{StDev}_i(A^{act}_i)$, where StDev_i is the standard deviation over the (repeated) actual attenuations (or total loss values) A^{act}_i .

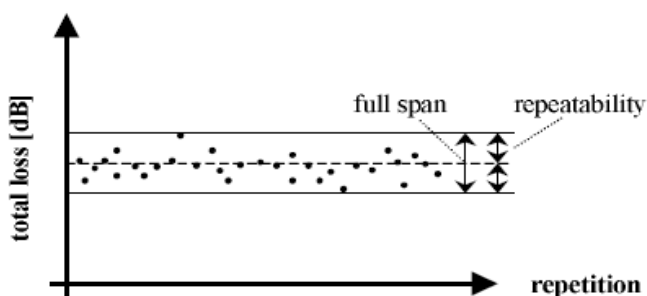

Conditions: Constant operating conditions. Operating in *power setting mode* requires zeroing prior to measurement (attenuators with power control only).

Resolution

The minimum addressable and displayable attenuation steps.

Return Loss

Ratio between incident power and reflected power, expressed in dB. Applicable to both attenuator ports, with the respective second port terminated (zero reflectance).

Conditions: Jumper cables with high quality connectors in perfect optical condition on both attenuator ports.

Measurement: With return loss meter and non-coherent source of applicable wavelength.

NOTE The measurement result includes internal reflections in the attenuator, such as reflections from both attenuator ports and, if the shutter is closed, reflection from the shutter.

Settling Time

Maximum time needed to change the attenuation by a specified step, from the beginning until the end of the change.

NOTE Settling time excludes the time needed for the interpretation of the command and for the internal communication between the mainframe and the attenuator module.

Shutter Isolation

Ratio between transmitted powers with open and with closed shutter, at a displayed attenuation of 0 dB, expressed in dB.

NOTE For another displayed attenuation, the isolation is increased by the attenuation.

Spectral ripple

Spectral ripple is a periodic change of the *total loss* as a function of the input wavelength when using a coherent light source. The spectral ripple is \pm half the span between the maximum and the minimum total loss, expressed in dB.

Spectral ripple does not include *attenuation flatness* or *insertion loss flatness*.

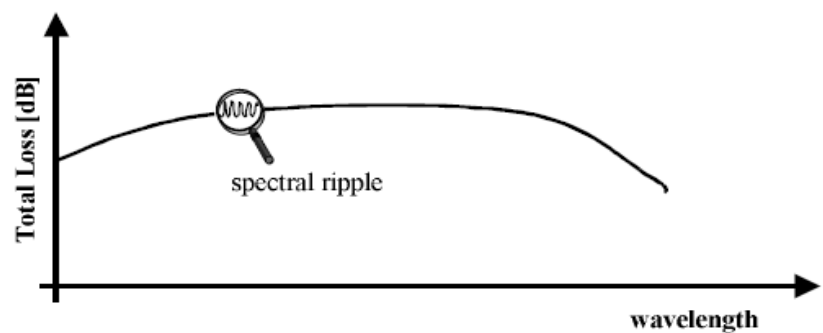

Conditions: Constant operating conditions. Linewidth as specified.

NOTE Spectral ripple results from interference between the passing wave and spurious internal reflections.

Total loss

The change of power level after inserting the attenuator between two connectorized patchcords, at an arbitrary attenuation setting, expressed in dB. Its value TL can be calculated from:

$$TL[\text{dB}] = 10 \log \frac{P_a}{P_b} = P_a[\text{dBm}] - P_b[\text{dBm}]$$

where:

P_a = power measured at the end of the two patchcords.

P_b = power measured after the insertion of the attenuator.

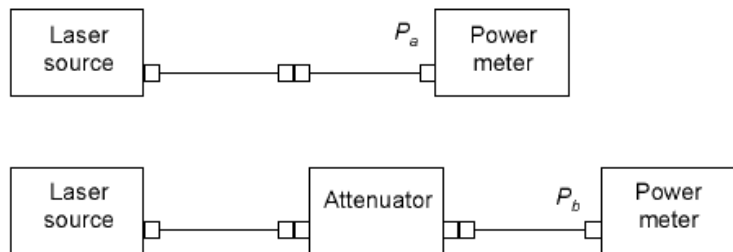

Conditions: Patchcord cables with high quality connectors in perfect optical condition on both attenuator ports.

NOTE The total loss depends on the attenuation setting.

NOTE Total loss includes the loss of one additional connector pair.

Transition speed

Specifies the settable attenuation change rate of the attenuator.

Wavelength Range

The range of wavelengths that can be set at the attenuator and for which the specifications apply (if not differently stated).

Specifications

The following Specifications tables are provided:

- **“Variable optical attenuator modules for single mode applications”** on page 43, which describes the Agilent 81570A, Agilent 81571A.
- **“Variable optical attenuator modules with power control for single mode applications”** on page 45, which describes the Agilent 81576A and Agilent 81577A.
- **“Variable optical attenuator modules for multimode applications”** on page 46, which describes the Agilent 81578A.

- this page deliberately blank -

Table 1 Variable optical attenuator modules for single mode applications

	81570A	81571A
Connectivity	straight connector versatile interface	angled connector versatile interface
Fiber type	9/125 μm SMF28	9/125 μm SMF28
Wavelength range	1200-1700 nm	
Attenuation range	0-60 dB	
Resolution	0.001 dB	
Repeatability ¹	± 0.01 dB	
Accuracy (uncertainty) ^{1, 2, 3, 4}	± 0.1 dB	
Settling time ⁵	typ. 100 ms	
Transition speed	typ. 0.1 ... 12 dB/s	
Attenuation flatness ^{1, 4, 6, 8}	< ± 0.07 dB (typ. ± 0.05 dB) for $1520 \text{ nm} < \lambda < 1620 \text{ nm}$ typ. ± 0.10 dB for $1420 \text{ nm} < \lambda < 1640 \text{ nm}$	
Spectral ripple ⁷	typ. ± 0.003 dB	
Insertion loss ^{2, 4, 9, 10}	typ. 0.7 dB excluding connectors < 1.6 dB (typ. 1.0 dB) including connectors ¹¹	
Insertion loss flatness ^{1, 4, 11}	typ. ± 0.1 dB for $1420 \text{ nm} < \lambda < 1615 \text{ nm}$	
Polarization dependent loss ^{2, 9, 11}	< 0.08 dBpp (typ. 0.03 dBpp)	
Polarization extinction ratio	N/A	
Return loss ^{9, 11}	typ. 45 dB	typ. 57 dB
Maximum input power ¹³	+ 33 dBm	
Shutter isolation	typ. 100 dB	
Dimensions (H x W x D)	75 mm x 32 mm x 335 mm (2.8" x 1.3" x 13.2")	
Weight	0.9 kg	
Recommended recalibration period	2 years	
Operating temperature	10 °C - 45 °C	
Humidity	Non-condensing	
Warm-up time	30 min.	

Table 1 Variable optical attenuator modules for single mode applications

<p>¹ At constant temperature</p> <p>² Temperature within $23^{\circ} \pm 5$ K</p> <p>³ Input power < +30 dBm; $\lambda = 1550$ nm \pm 15 nm; typical for 1250 nm < λ < 1650 nm</p> <p>⁴ For unpolarized light (SMF versions), or polarized light with TE mode injected in the slow axis (PMF version)</p> <p>⁵ Stepsize < 1 dB; for full range: typ. 6 s</p> <p>⁶ Relative to reference at 0 dB attenuation</p> <p>⁷ Linewidth of source > 100 MHz</p> <p>⁸ I disp set to 1550 nm; attenuation \leq 20 dB; for attenuation >20 dB: add typ. 0.01 dB (a [db] - 20) for 1520 nm < λ < 1620 nm add typ. 0.02 dB (a [db] - 20) for 1420 nm < λ < 1640 nm</p>	<p>⁹ For $\lambda = 1550$ nm \pm 15 nm</p> <p>¹⁰ Add typ. 0.1 dB for $\lambda = 1310$ nm \pm 15 nm</p> <p>¹¹ Measured with Agilent reference connectors</p> <p>¹² Excluding connectors, measured with a broadband source.</p> <p>¹³ Agilent Technologies Deutschland GmbH assumes no responsibility for damages caused by scratched or poorly cleaned connectors.</p>
---	--

Table 2 Variable optical attenuator modules with power control for single mode applications

	81576A		81577A	
Connectivity	straight connector, versatile interface		angled connector, versatile interface	
Fiber type	9/125 μ m SMF			
Wavelength range	1250-1650 nm			
Attenuation range	0-60 dB			
Resolution	0.001 dB			
	Attenuation Setting	Power Setting	Attenuation Setting	Power Setting
Repeatability ¹	± 0.010 dB	± 0.015 dB ²	± 0.010 dB	± 0.015 dB ²
Accuracy (uncertainty) ^{1, 3, 4, 5}	± 0.1 dB		± 0.1 dB	
Settling time ⁶	typ. 100 ms	typ. 300 ms	typ. 100 ms	typ. 300 ms
Transition speed	typ. 0.1 ... 12 dB/s			
Relative power meter uncertainty ⁷	± 0.03 dB ± 200 pW ⁸			
Attenuation flatness ^{1, 5, 9, 10}	< ± 0.07 dB (typ. ± 0.05 dB) for 1520 nm < λ < 1620 nm typ. ± 0.10 dB for 1420 nm < λ < 1640 nm			
Spectral ripple ¹¹	typ. ± 0.003 dB			
Insertion loss ^{3, 5, 12, 13}	typ. 0.9 dB excluding connectors < 1.8 dB (typ. 1.2 dB) including connectors ¹⁴			
Insertion loss flatness ^{1, 5, 14}	typ. ± 0.1 dB for 1420 nm < λ < 1615 nm			
Polarization dependent loss ^{3, 12, 14}	< 0.10 dBpp (typ. 0.05 dBpp)			
Return loss ^{12, 14}	typ. 45 dB		typ. 57 dB	
Maximum input power ¹⁵	+ 33 dBm			
Shutter isolation	typ. 100 dB			
Dimensions (H x W x D)	75 mm x 64 mm x 335 mm (2.8" x 2.6" x 13.2")			
Weight	1.3 kg			
Recommended recalibration period	2 years			
Operating temperature	10 °C - 45 °C			
Humidity	Non-condensing			
Warm-up time	30 min.			
¹ At constant temperature		⁹ Relative to reference at 0 dB attenuation		
² Output power > - 40 dBm, input power < +27 dBm, for input power > +27 dBm add typically ± 0.01 dB		¹⁰ λ disp set to 1550 nm; attenuation ≤ 20 dB; for attenuation > 20 dB: add typ. 0.01 dB (a [db] - 20) for 1520 nm < λ < 1620 nm add typ. 0.02 dB (a [db] - 20) for 1420 nm < λ < 1640 nm		
³ Temperature within 23 °C ± 5 K,		¹¹ Linewidth of source ≥ 100 MHz		
⁴ Input power < + 30 dBm; $\lambda = 1550$ nm ± 15 nm; typical for 1250 nm < λ < 1650 nm		¹² For $\lambda = 1550$ nm ± 15 nm		
⁵ For unpolarized light		¹³ Add typ. 0.1 dB for $\lambda = 1310$ nm ± 15 nm		
⁶ Stepsize < 1 dB; for full range: typ. 6 s		¹⁴ Measured with Agilent reference connectors		
⁷ Wavelength and SOP constant; temperature constant and between 23 °C ± 5 K; $\lambda < 1630$ nm		¹⁵ Agilent Technologies Deutschland GmbH assumes no responsibility for damages caused by scratched or poorly cleaned connectors.		
⁸ Input power $\leq + 27$ dBm, for input power > +27 dBm add ± 0.02 dB				

Table 3 Variable optical attenuator modules for multimode applications

	81578A #050	81578A #062
Connectivity	straight connector, versatile interface	straight connector, versatile interface
Fiber type	50/125 μm MMF	62.5/125 μm MMF
Wavelength range	700-1400 nm	
Attenuation range	0-60 dB	
Resolution	0.001 dB	
Repeatability ^{1, 2, 5}	± 0.015 dB	
Accuracy (uncertainty) ⁵	typ. ± 0.15 dB ± 0.2 dB	
Settling time ⁶	typ. 100 ms	
Transition speed	typ. 0.1 ... 12 dB/s	
Insertion loss ^{1, 2, 4, 5}	typ. 1.0 dB for NA = 0.1 2.0 dB for NA = 0.2, (typ. 1.3 dB)	typ. 1.0 dB for NA = 0.1 2.0 dB for NA = 0.2, (typ. 1.3 dB) typ. 3.0 dB for NA = 0.27
Return loss ^{2, 5, 7}	typ. 27 dB	
Maximum input power ⁸	+ 27 dBm	
Shutter isolation	typ. 100 dB	
Dimensions (H x W x D)	75 mm x 64 mm x 335 mm (2.8" x 2.6" x 13.2")	
Weight	0.9 kg	
Recommended recalibration period	2 years	
Operating temperature	10 °C - 45 °C	
Humidity	Non-condensing	
Warm-up time	30 min.	

¹ Under constant conditions

² Effective spectral bandwidth of source > 5 nm

³ For mode launch conditions with NA = 0.2; for every $\Delta\text{NA} = 0.01$ add typ. ± 0.01 dB

⁴ Temperature within 20°C \pm 5K and un polarized light

⁵ At 850 nm \pm 15 nm, 1310 nm \pm 15 nm

⁶ Step size < 1 dB; for full range: typ. 6 s

⁷ The return loss is mainly limited by the return loss of the front panel connectors

⁸ Agilent Technologies Deutschland GmbH assumes no responsibility for damages caused by scratched or poorly cleaned connectors.



Performance Tests

The performance tests in this section test the optical performance of the Agilent 8157xA modular Optical Switches. The complete specifications to which the instrument is tested are given in "Specifications" on page 31.

All tests can be performed without access to the interior of the instrument. The performance tests refer specifically to tests using an Agilent reference connector.

Required Test Equipment

The equipment required for the performance test is listed in Table 4. Any equipment that satisfies the critical specifications of the equipment given in Table 4 may be substituted for the recommended models.

Table 4 Equipment Required

Instrument/Accessory	Model	81570A	81571A	81576A	81577A	81578A		Required Characteristics	Alternative Models
						# 050	# 062		
Lightwave Multimeter	Agilent 8163A/B	x	x	x	x	x	x	2 x (4 slots)	8164A/B
Laser Source Module FP	Agilent 81654A	x	x	x	x	-	-	1550 nm	
Tunable Laser Source Module	Agilent 81689A	x	x	x	x	-	-		81640A
Power Sensor Module	Agilent 81634B	x	x	x	x	-	-		
Interface Module	Agilent 81618A	x	x	x	x	x	x		
Optical Head	Agilent 81624B	x	x	x	x	x	x	low PDL	
Depolarizing Filter	Agilent 81000DF	x	x	x	x	-	-		
HMS-10 Optical Head Adapter	Agilent 81000AA	x	x	x	x	x	x		
Optical Attenuator	Agilent 81561A	-	-	x	x	-	-		8156A #201
Return Loss Module	Agilent 81612A	x	x	x	x	-	-		
Reference Cable	Agilent 81610CC	x	x	x	x	-	-		
Polarization Controller	Agilent 11896A #022	x	x	x	x	-	-		8169A #022
Single Mode Fiber	Agilent 81101AC	x	-	x	-	-	-	HMS-10(s) to HMS-10(s)	
Single Mode Fiber	Agilent 81113SC	x	x	x	x	-	-	DIN(a) to DIN(a)	
Single Mode Fiber	Diamond 253-117-003L002	x	x	x	x	-	-	DIN(a) to HMS-10(s)	
Single Mode Fiber	Diamond 117-183-003L002	x	x	x	x	-	-	DIN(a) to FC/PC(a)	
Single Mode Fiber	Diamond 253-183-003L002	-	-	-	-	-	-	FC/PC(a) to HMS-10(s)	
Connector interface HMS-10	Agilent 81000AI	x	-	x	-	x	x		
Connector interface FC/PC	Agilent 81000FI	-	-	-	-	x	x	N-key	
Connector interface FC/APC	Agilent 81000NI	-	-	-	-	-	-	R-key	

Table 4 **Equipment Required**

Instrument/Accessory	Model							Required Characteristics	Alternative Models
		81570A	81571A	81576A	81577A	81578A # 050	81578A # 062		
Connector interface DIN	Agilent 81000SI	x	x	x	x	-	-		
DIN Feedthrough Adapter	1005-0255	-	x	-	x	-	-		
FC/PC Feedthrough Adapter	1005-0256	-	-	-	-	-	-		
HMS-10 Universal Adapter	81000UM	x	-	x	-	x	x		
FP-Source, 850nm, MM	81655A_E01	-	-	-	-	x	x		81551MM
FP-Source, 1310nm, SM	81655A	-	-	-	-	x	x		81657A
Optical Head 850nm	81623B_E01	-	-	-	-	x	x		81520A
Mode Conditioner	81578-63201 (Note 1)	-	-	-	-	x	x		
Mode Stripper, 50um	81578-63202 (Note 2)	-	-	-	-	x	-		

NOTE: 1. Diamond AMCB - 180 - 000V050

2. Service tool, only available for Agilent service centers. Not available for trade sales.

Legend:

- x necessary
- not applicable
- o optional
- (a) angled physical contact
- (s) straight physical contact

Test Record

Results of the performance test may be tabulated on the Test Record provided at the end of the test procedures. It is recommended that you fill out the Test Record and refer to it while executing the test. Since the test limits and setup information are printed on the Test Record for easy reference, the record can also be used as an abbreviated test procedure (if you are already familiar with the test procedure). The Test Record can also be used as a permanent record and may be reproduced without written permission from Agilent Technologies. The Test Record states rejection limits for the supplementary characteristics (typical specifications).

Test Failure

If the Agilent 8157xA High Power Optical Attenuator module fails any performance test, return the instrument to the nearest Agilent Technologies Sales/Service Office for repair.

Instrument Specification

Specifications are the performance characteristics of the instrument that is certified. These specifications, listed in "Variable optical attenuator modules for single mode applications" on page 43 are the performance standards or limits against which the Agilent 8157xA can be tested.

Any changes in the specification due to manufacturing changes, design, or traceability to the National Institute of Standards and Technology (NIST), will be covered in a manual change supplement, or revised manual. Such specifications supersede any that were previously published.

Performance Test Procedure

The performance test given in this section includes the Attenuation Repeatability Test. Perform each step in the order given, using the corresponding test equipment.

Operate the Agilent 81576A and 81577A Attenuator modules as attenuators and switch the power control loop off if not otherwise mentioned.

WARNING

Make sure that all optical connections of the test setup given in the procedure are dry and clean. **DO NOT USE INDEX MATCHING OIL.** Make sure that all optical connectors are undamaged.

For cleaning, use the cleaning instructions given in "Cleaning Information" on page 77.

Make sure that all optical cables of the test setup are fixed to the table so that they won't move during measurements.

Movement of the fibers during the test procedures and the quality of optical connectors affect the result of power measurements.

The environmental conditions (temperature and relative humidity) must remain constant during the test.

Insertion Loss Test

Carry out the following Insertion Loss Test at 1550 nm (81578A at 850 nm and 1310 nm) with single mode fibers using the equipment listed in [Table 4](#) on page 48. To adapt for the straight or angled contact versions of the optical switch use patchcords with appropriate connectors and suitable connector interfaces.

1. Turn the instruments on and allow the devices to warm up (20...30 min).
2. Make sure that all your connectors are clean and undamaged.
3. Connect the equipment as shown in [Figure 9](#).

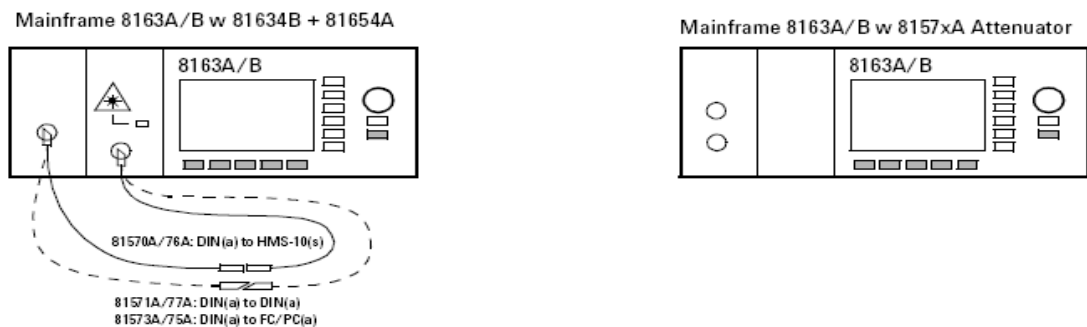

Insertion Loss Reference setup for SM attenuators

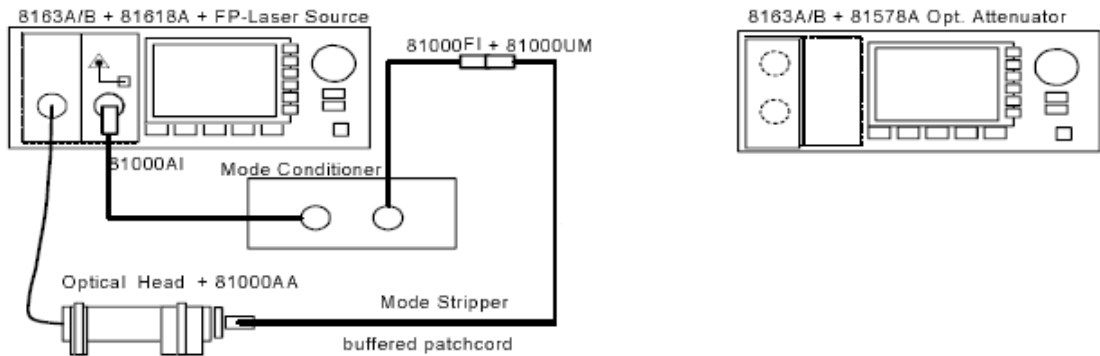

Setup for MM attenuators

Figure 9 Insertion Loss Reference

- 1 Set the attenuator and the power meter to the actual wavelength of the laser source.
- 2 Disable the laser source, zero the power meter and select Autorange. Display [dB].
- 3 Set the power meter averaging time to 500 ms.
- 4 Enable the laser source and set Display to Reference on the power meter.
- 5 Set attenuation [a] to 0 dB and open the shutter.
- 6 Record the power meter reading (in dB) as Insertion Loss in the Test Record.
- 7 Connect the equipment as shown in [Figure 10](#) on page 53.

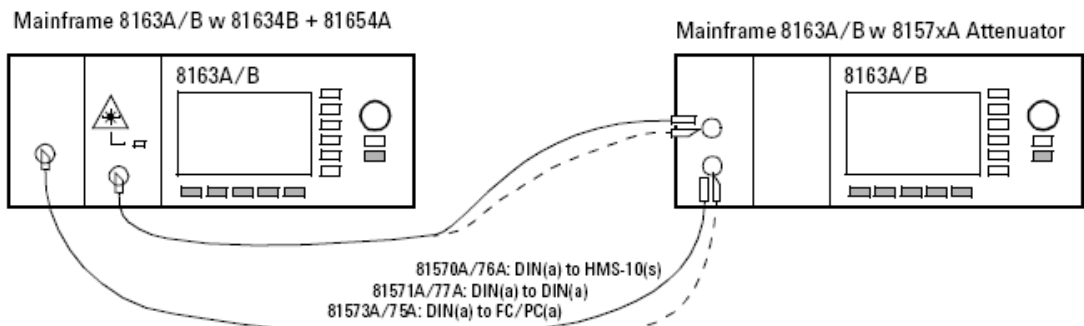

Setup for SM attenuators

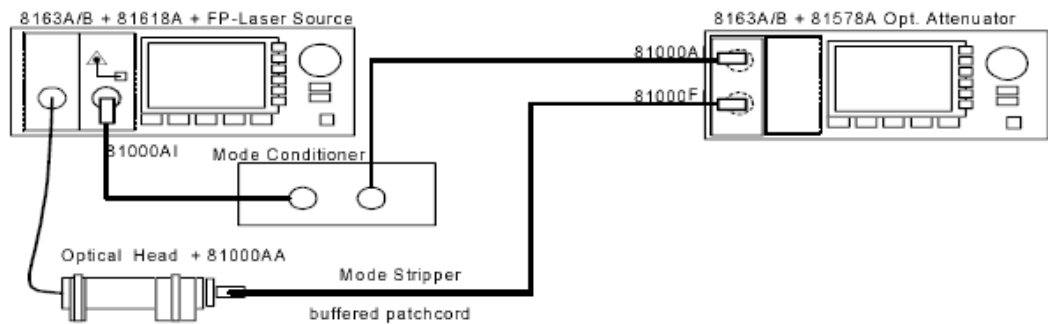

Setup for MM attenuators

Figure 10 Insertion Loss Test

Accuracy test

Use the same equipment and test setup as used in [Figure 10](#) on page 53

- 1 Turn the instruments on and allow the devices to warm up (20 to 30 min.).
- 2 Make sure that all your connectors are clean and undamaged.
- 3 Set the attenuator and the power meter to the actual wavelength of the laser source.
- 4 Disable the laser source, zero the power meter and select Autorange. Display [dB].
- 5 Enable the laser source, open the shutter and set the attenuation [a] to dB.
- 6 Set display to Reference on the power meter.
- 7 Set the attenuation [a] to the different values listed below and note the power meter reading in the test record.

1 dB	2 dB	3 dB	4 dB	5 dB
6 dB	7 dB	8 dB	9 dB	10 dB
11 dB	12 dB	13 dB	14 dB	15 dB
25 dB	35 dB	45 dB	55 dB	60 dB

Repeatability Test

Use the same equipment and test set up as used in [Figure 10](#).

- 1 Turn the instruments on and allow the devices to warm up (20..30 min).
- 2 Make sure that all your connectors are clean and undamaged.
- 3 Set the attenuator and the power meter to the actual wavelength of the laser source.
- 4 Disable the laser source, zero the power meter and select Autorange. Display [dB].
- 5 Enable the laser source and open the shutter.
- 6 Set the attenuation [a] to 1 dB, wait until it settles and set Display to Reference on the power meter.
- 7 Set the attenuation [a] to any other value (e.g. 21 dB) and wait until it settles at this value.
- 8 Change the attenuation [a] back to the previous value and note the deviation in the Test Record.
- 9 Repeat step 3 to step 5 for the following attenuation settings:

7 dB	15 dB	24 dB	32 dB
40 dB	48 dB	54 dB	60 dB

Power Setting Repeatability Test

Use the same equipment and test setup as used in [Figure 10](#) on page 53 without the Agilent 81634B Power Meter. The performance test can be performed at other wavelengths than 1550 nm.

- 1 Turn the instruments on and allow the devices to warm up (20..30 min).
- 2 Make sure that all your connectors are clean and undamaged.
- 3 Set the attenuator to the actual wavelength of the laser source and set the averaging time to 1 sec.
- 4 Zero the attenuator power meter, disable the power control and Display [dBm].
- 5 Enable the laser source and open the shutter.
- 6 Set [P_{SET}] to 0 dBm and wait for it to stabilize. Note the reading of [P_{ACT}] in the Test Record.
- 7 Set [P_{SET}] to any other value and wait for it to settle.
- 8 Change [P_{SET}] back to the previous value and note the deviation of [P_{ACT}] in the Test Record.
- 9 Repeat step 6 to step 8 for [P_{SET}] = -25 dBm and [P_{SET}] = -50 dBm.

Wavelength Flatness Test (Not applicable to 81578A)

Use the same test setup as used in [Figure 10](#) on page 53 but replace the Agilent 81654A Fabry Perot Laser Source with the Agilent 81689A Tunable laser Source.

- 10** Turn the instruments on and allow the devices to warm up (20..30 min).
- 11** Make sure that all your connectors are clean and undamaged.
- 12** Connect the equipment as shown in [Figure 10](#) on page 53.
- 13** Make sure that the power meter and tunable laser source are hosted by the same mainframe.
- 14** Start the PACT application by pressing the [APPL] button on the mainframe and selecting PACT.
- 15** Select the modules and the sweep parameters as follows:
I Start = 1524.0 nm
I Stop = 1576.0 nm
Step = 0.1 nm
 $P_{\max} = 0.000$ dBm
- 16** Press [Reference] and in the next screen [New Ref] and start the reference measurement.
- 17** Return to the setup menu by pressing [Menu] and selecting [Setup].
- 18** Connect the equipment as shown in [Figure 9](#) on page 52.
- 19** Set the attenuation to 15 dB.
- 20** Press [Measure] to start the DUT measurement.
- 21** After completion press [Graph] to enter the Trace Display.
- 22** Use the markers C and D to mark the maximum and minimum Insertion Loss peak and note the power difference D in the Test Record.

Return Loss Test (Not applicable to 81578A)

Carry out the following Return Loss Test at 1550 nm with single mode fibers using the equipment listed in Table 4, "Equipment Required," on page 48. To adapt for the straight or angled contact versions of the attenuator, use patchcords with appropriate connectors and suitable connector interfaces.

- 1** Turn the instruments on and allow the devices to warm up (20...30 min).
- 2** Make sure that all your connectors are clean and undamaged.

3 Connect the equipment as shown in Figure 11.



Figure 11 Return Loss Reference Setup for SM attenuators

- 4 Set the attenuator and the power meter to the actual wavelength of the internal laser source of the return loss meter.
- 5 Disable the internal laser source, cover the end of the reference cable and zero the return loss meter.
- 6 Uncover the clean end of the reference cable and enable the laser source.
- 7 Select the REF CAL parameter and set the reflection reference R to 14.7 dB, the default value for the return loss of the reference reflector cable 81610CC.
- 8 Set Display to Reference. The value read should now be 14.7 dB, the same as the value entered for reflection reference R.
- 9 Select the REF AUX parameter and terminate the reference cable by wrapping the fiber several times around a rod with a diameter around 5 mm (such as a screwdriver shaft, or a pencil).
- 10 Set Display to reference to set the termination parameter.
- 11 Remove the reference cable and reconnect the equipment as shown in Figure 12.

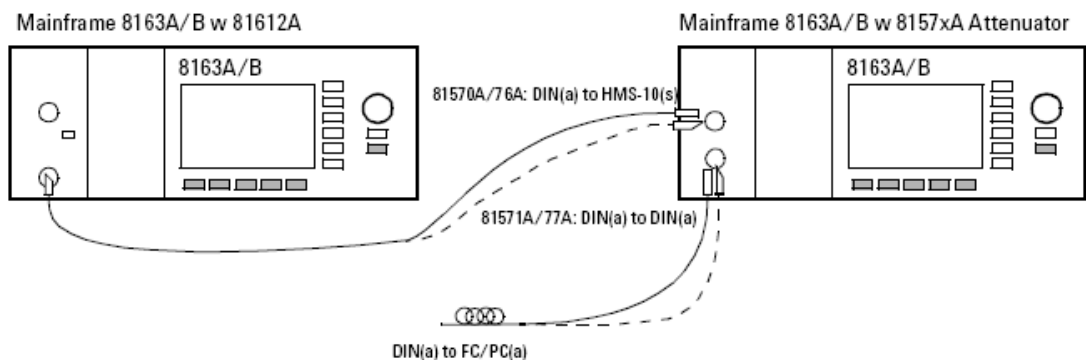

Figure 12 Return Loss Test Setup for SM attenuators

- 12 Terminate the patchcord on the attenuator output by wrapping the fiber several times around a rod with a diameter around 5 mm (such as a screwdriver shaft, or a pencil). Do the same for the monitor output if applicable.

- 13 Set the attenuation [a] to 0 dB and note the input return loss in the Test record.
- 14 Open the shutter and record the return loss in the Test Record.
- 15 Connect the return loss meter to the attenuator output port and terminate the input port as described in step 12
- 16 You may measure the output return loss for open and closed shutter or for other arbitrary attenuation settings as described in step 13 and step 14 .

Polarization Dependent Loss (PDL) Test - Scanning Method (Not applicable to 81578A)

Carry out the following PDL Test at 1550 nm with single mode fibers using the equipment listed in [Table 4](#) on page 48. To adapt for the straight or angled contact versions of the switch use patchcords with appropriate connectors and suitable connector interfaces.

WARNING

This test is recommended for the fiber loop-type 11869A Polarization Controller. For plate-type Polarization Controller 8169A refer to section "Polarization Dependent Loss (PDL) Test - Mueller Method (Not applicable to 81578A)" on page 58.

- 1 Turn the instruments on and allow the devices to warm up (20..30 min).
- 2 Make sure that all your connectors are clean and undamaged.
- 3 Connect the equipment as shown in [Figure 13](#)

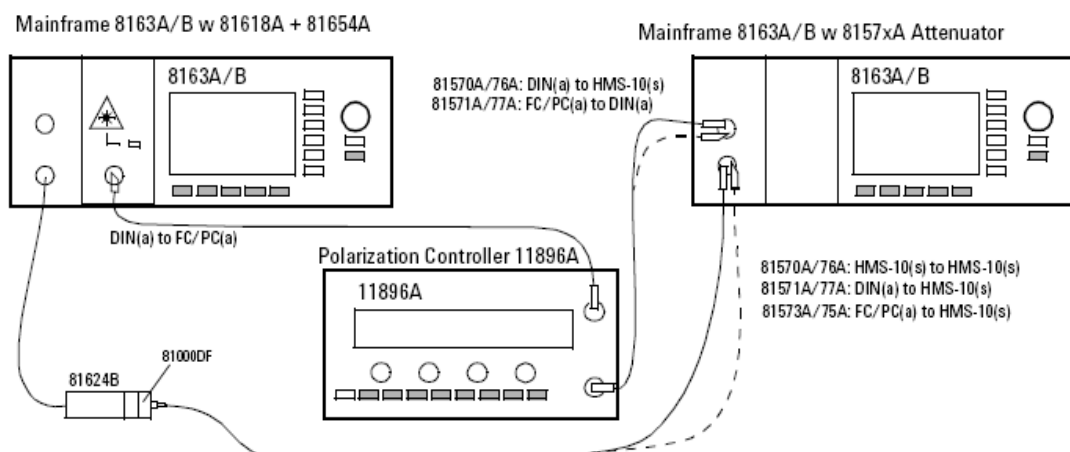

Figure 13 PDL Test Setup - Scanning Method for SM attenuators

WARNING

The patchcords to and from the polarization controller and the attenuator must not move during a measurement, or between any measurements. Use tape to fix the fibers to the table.

- 4** Set the attenuator to the wavelength of the laser source.
- 5** Enable the laser source, and open the shutter of the attenuator.
- 6** Display [dB] at the power meter and set Display to reference.
- 7** Choose the power meter Stability Application and set the parameters as follows:
 - Total Time -25 seconds
 - Averaging Time -50 ms
 - Wavelength -Source wavelength
 - Range Mode -auto
- 8** Set the 11896A Polarization Controller scan rate = 4 and press [AutoScan] to start Polarization Scrambling.
- 9** Press Measure at the power meter to start PDL Scanning.
- 10** After the measurement press [Analysis] and [More] to get the power readings.
- 11** Note the results in the Test Record.

Polarization Dependent Loss (PDL) Test - Mueller Method (Not applicable to 81578A)

Carry out the following PDL Test at 1550 nm with single mode fibers using the equipment listed in [Table 4](#) on page 48. To adapt for the straight or angled contact versions of the attenuator use patchcords with appropriate connectors and suitable connector interfaces. Use the operation mode Attenuation Set

WARNING

Perform this test with the plate-type 8169A Polarization Controller.

- 1** Turn the instruments on, and allow the devices to warm up (20...30 min).
- 2** Make sure that all your connectors are clean and undamaged.
- 3** Connect the equipment as shown in [Figure 14](#)

Figure 14 PDL Reference Setup for SM attenuators

WARNING

The patchcords to and from the polarization controller and the attenuator must not move during a measurement, or between any measurements. Use adhesive tape to fix the fibers to the table.

- 4 Zero the power meter. Display [W].
- 5 Set the attenuator and the power meter to the actual wavelength of the source.
- 6 Enable the laser source and allow 5 minutes for the laser to settle.
- 7 Reset the polarization controller.
- 8 Set the polarization filter of the 8169A to maximize the signal.
- 9 Note the displayed angle of the polarization filter as "Linear Horizontal Setting".

WARNING

Set plates for Horizontal polarization. For the following steps the polarizer is kept constant.

- 10 Set the $\lambda/4$ Retarder Plate to the same angle as the polarization filter.
- 11 Note the angle as $\lambda/4$ "Linear Horizontal Polarization"
- 12 Set the $\lambda/2$ Retarder Plate to the same angle as the polarization filter.
- 13 Note the angle as $\lambda/2$ "Linear Horizontal Polarization".

Determine settings for Linear Vertical, Linear Diagonal, and Right Hand Circular Polarization.

WARNING

In order to get the required polarization, the $\lambda/2$ and $\lambda/4$ retarder plates need to be set to the appropriate values. The corrected positions of the polarizer plates depend on the actual wavelength and have to be taken from Table 5, "Retarder Settings," on page 62.

WARNING

In the case of Linear Horizontal polarized light no correction is to be made. The table lists corrections for every 20 nm step. For wavelengths between listed values, a linear approximation should be used.

- 14 Get the values (possible by approximation) for the wavelength dependent offset positions for each type of polarization from Table 5, "Retarder Settings," on page 62.
- 15 Add these values to those for Linear Horizontal polarized light.

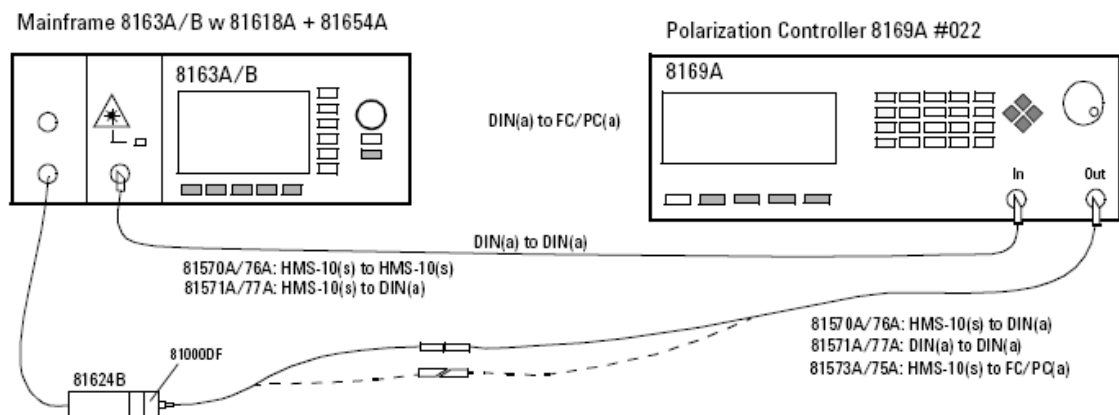

- 16** Note the calculated corrected wavelength dependent position values in the Test Record for the $\lambda/4$ Plate setting and the $\lambda/2$ Plate setting for Linear Vertical, Linear Diagonal, and Right Hand Circular Polarization.

Measure the Reference Power

- 17** Keep the settings from the polarizer and the $\lambda/4$ and $\lambda/2$ Retarder Plates from step 5, step 6 and step 12 for Linear Horizontal polarized light.
- 18** Note the power reading as Reference Power P_1 in the Test Record.
- 19** Set the $\lambda/4$ and $\lambda/2$ Retarder Plates to the corrected wavelength dependent positions for Linear Vertical polarized light.
- 20** Read the power on the power meter and note as Reference Power P_2 in the Test Record.
- 21** Set the $\lambda/4$ and $\lambda/2$ Retarder Plates to the corrected wavelength dependent positions for Linear Diagonal polarized light.
- 22** Note the power reading as Reference Power P_3 in the Test Record.
- 23** Set the $\lambda/4$ and $\lambda/2$ Retarder Plates to the corrected wavelength dependent positions for Right Hand Circular polarized light.
- 24** Note the power reading as Reference Power P_4 in the Test Record.
- 25** Connect the equipment as shown in [Figure 15](#)

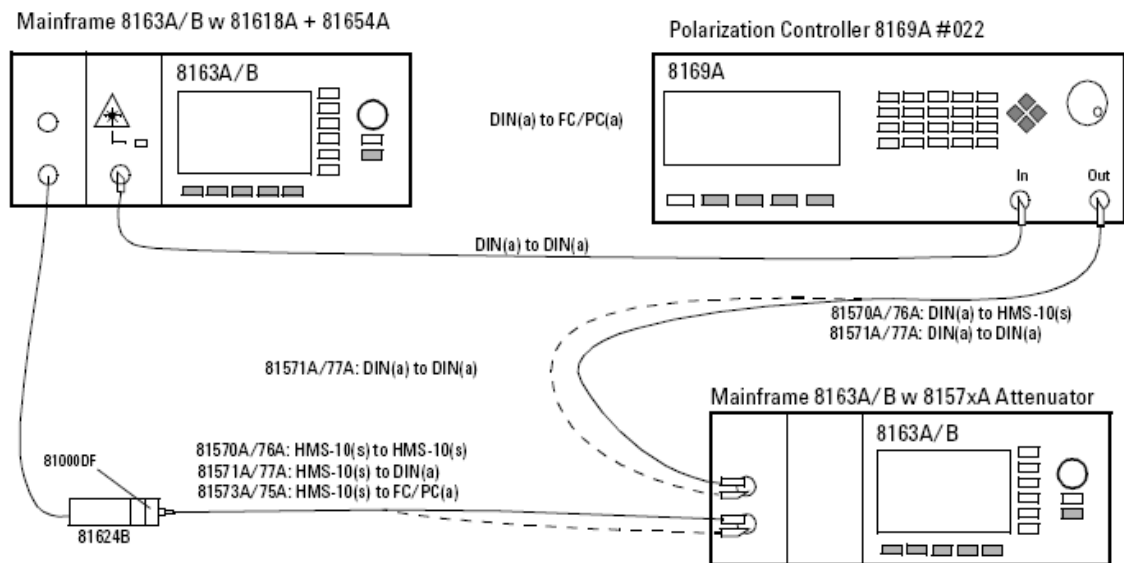

Figure 15 PDL Test Setup - Mueller method

WARNING

The patchcords to and from the polarization controller and the attenuator must not move during, or between measurements. Use adhesive tape to fix the fibers to the table.

Measure the Optical Power after the Attenuator Module

- 26 Open the shutter of the attenuator.
- 27 Set the $\lambda/4$ and $\lambda/2$ Retarder Plates for Linear Horizontal polarized light.
- 28 Note the power reading as DUT Power P_1 in the Test Record.
- 29 Set the $\lambda/4$ and $\lambda/2$ Retarder Plates to the corrected wavelength dependent positions for Linear Vertical polarized light.
- 30 Note the power displayed on the power meter as DUT Power P_2 in the Test Record.
- 31 Set the $\lambda/4$ and $\lambda/2$ Retarder Plates to the corrected wavelength dependent positions for Linear Diagonal polarized light.
- 32 Note the power reading as DUT Power P_3 in the Test Record.
- 33 Set the $\lambda/4$ and $\lambda/2$ Retarder Plates to the corrected wavelength dependent positions for Right Hand Circular polarized light.
- 34 Note the power reading as DUT Power P_4 in the Test Record.
- 35 Calculate the Mueller coefficients, the maximum and minimum transmission and finally the Polarization Dependent Loss (PDL) as described in the Test Record.

Table 5 Retarder Settings

$\lambda/v\mu$	Linear Vertical		Linear Diagonal		Right hand circular	
	$\lambda/4$ Plate	$\lambda/2$ Plate	$\lambda/4$ Plate	$\lambda/2$ Plate	$\lambda/4$ Plate	$\lambda/2$ Plate
1580	2.5°	46.2°	1.7°	23.3°	42.9°	-17.1°
1560	1.2°	45.6°	0.8°	22.9°	44.0°	-16.5°
1540	0°	45.0°	0°	22.5°	45.0°	-15.1°
1520	-1.4°	44.3°	-1.0°	22.0°	46.2°	-13.8°
1500	-2.7°	43.6°	-2.0°	21.4°	47.4°	-12.4°

Relative Power Meter Uncertainty Test

This test applies to the Agilent 81576A and 81577A Attenuators with power control.

Carry out the following Power Meter Uncertainty Test at 1550 nm or another specified wavelength with single mode fibers using the equipment listed in [Table 4](#) on page 48. To adapt for the straight or angled contact versions of the attenuator use patchcords with appropriate connectors and suitable connector interfaces.



WARNING

Do not turn the laser off during the measurement! Clean all connectors carefully before you start with the measurement.

- 1 Turn the instruments on and allow the devices to warm up (20 to 30 min.).
- 2 Make sure that you perform this test in an environment with temperature fluctuations less than $\pm 1^\circ\text{C}$.
- 3 Make sure that all your connectors are clean and undamaged.
- 4 Connect the equipment as shown below in [Figure 16](#).

Figure 16 Relative Power Meter uncertainty Setup for SM attenuators

- 5 Set both attenuators to the wavelength of the source and disable them.
- 6 Set the attenuation [α] of 81570A reference attenuator to 55dB.
- 7 Set the attenuation [α] of the DUT attenuator to 0 dB.
- 8 Set the averaging time of the DUT attenuator power meter to 1 s.
- 9 Zero the reference and the attenuator power meter.
- 10 Enable the laser source and wait for it to stabilize (> 30 seconds).
- 11 Enable the attenuators.
- 12 Set the reference power meter to the wavelength of the source, set the averaging time to 1 s. and display [dB]. Press [Display to Reference].
- 13 Set the range mode of the reference power meter to *Manual*.
- 14 On the DUT attenuator edit *P Offset* until the parameter P_{SET} equals 0 dBm.
- 15 Lower P_{SET} and the attenuation of the reference attenuator by 5 dB.
- 16 Note the reference power meter reading in the Test record.
- 17 Repeat step 14 and step 15 until the reference attenuator shows an attenuation of 0 dB.
- 18 Perform step 14 and step 15 upward until the reference attenuator shows 55 dB.

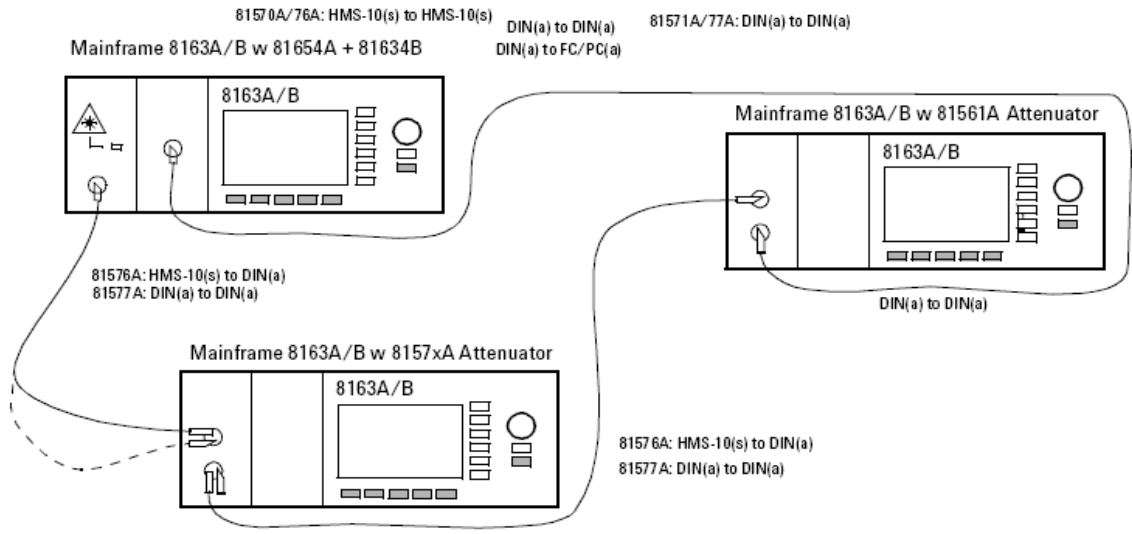

Agilent High Power Optical Attenuator Performance Test

Page 2 of 6

Agilent High Power Optical Attenuator

Report No.

Date:

Test Equipment

#	Description	Model No.	Trace No.	Cal. due date
1	Mainframe			/ /
2	Power Meter			/ /
3	Laser Source			/ /
4	Return Loss Module			/ /
5	Connector Interface			/ /
6	Single Mode Fiber			/ /
7				/ /
8				/ /
9				/ /
10				/ /
11				/ /
12				/ /
13				/ /
14				/ /
15				/ /
16				/ /
17				/ /
18				/ /
19				/ /
20				/ /

Agilent High Power Optical Attenuator Performance Test

Page 3 of 6

81570A/ 71A/ 76A/ 77A

Agilent High Power Optical Attenuator

Report No. _____

Date _____

Insertion Loss Test

Product	81570A/71A	81576A + 81577A
Measurement		
Upper test limit	1.5 dB	2.0 dB

Attenuation Accuracy Test

Setting/dB	Reading/dB	Deviation/dB
1		
2		
3		
4		
5		
6		
7		
8		
9		
10		
11		
12		
13		
14		
15		
25		
35		
45		
55		
60		
Most positive Deviation		
Upper test limit		+0.1 dB
Most negative Deviation		
Lower test limit		-0.1 dB

Agilent High Power Optical Attenuator Performance Test
 81570A/ 71A/ 76A/ 77A

Page 4 of 6

Agilent Modular Optical Attenuator

Report No. _____

Date _____

Attenuation Repeatability Test

Setting / dB	Deviation / dB
1	
7	
15	
24	
32	
40	
48	
54	
60	
Maximum peak-to-peak Deviation	
Upper test limit	0.02 dBpp

Power Setting Repeatability Test

Power Setting/dB	Deviation/dB
0 dBm	
-25 dBm	
-50 dBm	
Maximum peak-to-peak Deviation	
Upper test limit	0.03 dBpp

Wavelength Flatness Test

Product	8157xA
Measurement	
Upper test limit	0.14 dBpp

Return Loss Test

Product	81570A + 81576A	81571A/77A
Attenuation Setting		
Shutter State	Open	Closed
Measurement Input Port		
Measurement Output Port		
Lower test limit	42 dB	54 dB

Agilent High Power Optical Attenuator Performance Test

81570A/ 71A/ 76A/ 77A

Agilent High Power Optical Attenuator

Report No. _____

Date _____

Polarization Dependent Loss Test - Scanning method (11896A)

Product	81570A/71A	81576A + 81577A
Attenuation Setting		
Maximum peak-to-peak Deviation		
Upper test limit	0.8 dBpp	0.10 dBpp

Polarization Dependent Loss Test - Mueller method (8169A)

Attenuation setting: _____ dB

	Polarization			
	Linear Horizontal	Linear Vertical	Linear Diagonal	Right Hand Circular
Polarizer Setting	deg	n/a	n/a	n/a
$\lambda/4$ Plate Setting	deg	n/a	n/a	n/a
$\lambda/2$ Plate Setting	deg	n/a	n/a	n/a

	Corrected Wavelength dependent positions			
	Linear Horizontal	Linear Vertical	Linear Diagonal	Right Hand Circular
Polarizer Setting	n/a	deg	deg	deg
$\lambda/4$ Plate Setting	n/a	deg	deg	deg
$\lambda/2$ Plate Setting	n/a	deg	deg	deg

Measurement	P ₁	P ₂	P ₃	P ₄
Reference Power	μW	μW	μW	μW
DUT Power	μW	μW	μW	μW

Mueller Coefficients

$$\begin{aligned}
 m_{11} &= (P_{DUT1}/P_{REF1} + P_{DUT2}/P_{REF2})/2 &= & \underline{\hspace{2cm}} \\
 m_{12} &= (P_{DUT1}/P_{REF1} - P_{DUT2}/P_{REF2})/2 &= & \underline{\hspace{2cm}} \\
 m_{13} &= (P_{DUT3}/P_{REF3}) - m_{11} &= & \underline{\hspace{2cm}} \\
 m_{14} &= (P_{DUT4}/P_{REF4}) - m_{11} &= & \underline{\hspace{2cm}}
 \end{aligned}$$

Minimum and maximum Transmission

$$\begin{aligned}
 T_{\max} &= m_{11} + \sqrt{m_{12}^2 + m_{13}^2 + m_{14}^2} &= & \underline{\hspace{2cm}} \\
 T_{\min} &= m_{11} - \sqrt{m_{12}^2 + m_{13}^2 + m_{14}^2} &= & \underline{\hspace{2cm}}
 \end{aligned}$$

Product	81570A/71A	81576A + 81577A
Polarization dependent loss PDL = 10lg(Tmax/Tmin) dBpp		
Upper test limit	0.8 dBpp	0.10 dBpp

Agilent High Power Optical Attenuator Performance Test

Page 6 of 6

81570A/ 71A/ 76A/ 77A

Agilent High Power Optical Attenuator

Report No. _____

Date _____

Relative Power Meter Uncertainty Test

8157xA [P _{SET}]/ dBm	Reference Attenuation/dB	Reference Reading 1 /dB	Reference Reading 2 /dB
0			
-5			
-10			
-15			
-20			
-25			
-30			
-35			
-40			
-45			
-50			
-55			
Maximum peak-to-peak deviation			
Upper test limit		0.06 dBpp	

Agilent High Power Optical Attenuator Performance Test

Page 3 of 4

81578A

Agilent High Power Optical Attenuator

Report No. _____

Date _____

Insertion Loss Test

Wavelength		850 nm		1310 nm
Measurement				
Upper test limit		1.5 dB		1.5 dB

Attenuation Accuracy Test

Wavelength Setting/dB	850 nm		1310 nm	
	Reading/dB	Deviation/dB	Reading/dB	Deviation/dB
1				
2				
3				
4				
5				
6				
7				
8				
9				
10				
11				
12				
13				
14				
15				
25				
35				
45				
55				
60				
Most Positive Deviation				
Upper test limit		+0.2dB		+0.2 dB
Most Negative Deviation				
Lower test limit		-0.2dB		-0.2 dB

Test Record

Agilent High Power Optical Attenuator Performance Test

Test Facility:

_____	Report No.:	_____
_____	Date:	_____
_____	Customer:	_____
_____	Tested By:	_____
Model: Agilent High Power Optical Attenuator	Product Number:	_____ # _____
Serial No. _____	Ambient temperature	_____ °C
Firmware Rev. _____	Relative humidity	_____ %
	Line frequency	_____ Hz

Special Notes: _____

Agilent High Power Optical Attenuator Performance Test

Page 2 of 4

Agilent High Power Optical Attenuator

Report No.

Date:

Test Equipment

#	Description	Model No.	Trace No.	Cal. due date
1	Mainframe			/ /
2	Power Meter			/ /
3	Laser Source			/ /
4	Return Loss Module			/ /
5	Connector Interface			/ /
6	Single Mode Fiber			/ /
7				/ /
8				/ /
9				/ /
10				/ /
11				/ /
12				/ /
13				/ /
14				/ /
15				/ /
16				/ /
17				/ /
18				/ /
19				/ /
20				/ /

Agilent High Power Optical Attenuator Performance Test

Page 4 of 4

81578A

Agilent Modular Optical Attenuator

Report No. _____

Date _____

Attenuation Repeatability Test

Wavelength	850 nm	1310 nm
Setting / dB	Deviation / dB	Deviation / dB
1		
7		
15		
24		
32		
40		
48		
54		
60		
Maximum peak-to-peak Deviation		
Upper test limit	0.03 dBpp	0.03 dBpp



Cleaning Information

The following Cleaning Information contains some general safety precautions, which must be observed during all phases of cleaning. Consult your specific optical device manuals or guides for full information on safety matters.

Please try, whenever possible, to use physically contacting connectors, and dry connections. Clean the connectors, interfaces, and bushings carefully after use.

If you are unsure of the correct cleaning procedure for your optical device, we recommend that you first try cleaning a dummy or test device.

Agilent Technologies assume no liability for the customer's failure to comply with these requirements.

Safety Precautions

Please follow the following safety rules:

- Do not remove instrument covers when operating.
- Ensure that the instrument is switched off throughout the cleaning procedures.
- Use of controls or adjustments or performance of procedures other than those specified may result in hazardous radiation exposure.
- Make sure that you disable all sources when you are cleaning any optical interfaces.
- Under no circumstances look into the end of an optical device attached to optical outputs when the device is operational. The laser radiation is not visible to the human eye, but it can seriously damage your eyesight.
- To prevent electrical shock, disconnect the instrument from the mains before cleaning. Use a dry cloth, or one slightly dampened with water, to clean the external case parts. Do not attempt to clean internally.
- Do not install parts or perform any unauthorized modification to optical devices.
- Refer servicing only to qualified and authorized personnel.

Why is it important to clean optical devices?

CAUTION

Optical power levels above 100 mW applied to single mode connectors can easily damage the connector if it is not perfectly clean. Also, scratched or poorly cleaned connectors can destroy optical connectors mechanically. Always make sure that your optical connectors are properly cleaned and unscratched before connection. However, Agilent Technologies Deutschland GmbH assumes no responsibility in case of an operation that is not compliance with the safety instructions as stated above.

In transmission links optical fiber cores are about 9 mm (0.00035") in diameter. Dust and other particles, however, can range from tenths to hundredths of microns in diameter. Their comparative size means that they can cover a part of the end of a fiber core, and thus degrade the transmission quality. This will reduce the performance of your system.

Furthermore, the power density may burn dust into the fiber and cause additional damage (for example, 0 dBm optical power in a single mode fiber causes a power density of approximately 16 million W/m²). If this happens, measurements become inaccurate and non-repeatable.

Cleaning is, therefore, an essential yet difficult task. Unfortunately, when comparing most published cleaning recommendations, you will discover that they contain several inconsistencies. In this chapter, we want to suggest ways to help you clean your various optical devices, and thus significantly improve the accuracy and repeatability of your lightwave measurements.

What materials do I need for proper cleaning?

Some Standard Cleaning Equipment is necessary for cleaning your instrument. For certain cleaning procedures, you may also require certain Additional Cleaning Equipment.

Standard Cleaning Equipment

Before you can start your cleaning procedure you need the following standard equipment:

- Dust and shutter caps

- Isopropyl alcohol
- Cotton swabs
- Soft tissues
- Pipe cleaner
- Compressed air

Dust and shutter caps

All of Agilent Technologies' lightwave instruments are delivered with either laser shutter caps or dust caps on the lightwave adapter. Any cables come with covers to protect the cable ends from damage or contamination.

We suggest these protective coverings should be kept on the equipment at all times, except when your optical device is in use. Be careful when replacing dust caps after use. Do not press the bottom of the cap onto the fiber too hard, as any dust in the cap can scratch or pollute your fiber surface.

If you need further dust caps, please contact your nearest Agilent Technologies sales office.

Isopropyl alcohol

This solvent is usually available from any local pharmaceutical supplier or chemist's shop. Results will vary depending on the purity of the alcohol.

If you use isopropyl alcohol to clean your optical device, do not immediately dry the surface with compressed air (except when you are cleaning very sensitive optical devices). This is because the dust and the dirt is dissolved in the alcohol and will leave behind filmy deposits after the alcohol has evaporated. You should therefore first remove the alcohol and the dust with a soft tissue, and then use compressed air to blow away any remaining filaments.

If possible avoid using denatured alcohol containing additives. Instead, apply alcohol used for medical purposes.

Never drink this alcohol, as it may seriously damage to your health.

Do not use any other solvents, as some may damage plastic materials and claddings. Acetone, for example, will dissolve the epoxy used with fiber optic connectors. To avoid damage, only use isopropyl alcohol.

Cotton swabs

We recommend that you use swabs such as Q-tips or other cotton swabs normally available from local distributors of medical and hygiene products (for example, a supermarket or a chemist's shop). You may be able to obtain various sizes of swab. If this is the case, select the smallest size for your smallest devices.

Ensure that you use natural cotton swabs. Foam swabs will often leave behind filmy deposits after cleaning.

Use care when cleaning, and avoid pressing too hard onto your optical device with the swab. Too much pressure may scratch the surface, and could cause your device to become misaligned. It is advisable to rub gently over the surface using only a small circular movement.

Swabs should be used straight out of the packet, and never used twice. This is because dust and dirt in the atmosphere, or from a first cleaning, may collect on your swab and scratch the surface of your optical device.

Soft tissues

These are available from most stores and distributors of medical and hygiene products such as supermarkets or chemists' shops.

We recommend that you do not use normal cotton tissues, but multi-layered soft tissues made from non-recycled cellulose. Cellulose tissues are very absorbent and softer. Consequently, they will not scratch the surface of your device over time.

Use care when cleaning, and avoid pressing on your optical device with the tissue. Pressing too hard may lead to scratches on the surface or misalignment of your device. Just rub gently over the surface using a small circular movement.

Use only clean, fresh soft tissues and never apply them twice. Any dust and dirt from the air which collects on your tissue, or which has gathered after initial cleaning, may scratch and pollute your optical device.

Pipe cleaner

Pipe cleaners can be purchased from tobacconists, and come in various shapes and sizes. The most suitable one to select for cleaning purposes has soft bristles, which will not produce scratches.

The best way to use a pipe cleaner is to push it in and out of the device opening (for example, when cleaning an interface). While you are cleaning, you should slowly rotate the pipe cleaner.

Only use pipe cleaners on connector interfaces or on feed through adapters. Do not use them on optical head adapters, as the center of a pipe cleaner is hard metal and can damage the bottom of the adapter.

Your pipe cleaner should be new when you use it. If it has collected any dust or dirt, this can scratch or contaminate your device.

The tip and center of the pipe cleaner are made of metal. Avoid accidentally pressing these metal parts against the inside of the device, as this can cause scratches.

Compressed air

Compressed air can be purchased from any laboratory supplier.

It is essential that your compressed air is free of dust, water and oil. Only use clean, dry air. If not, this can lead to filmy deposits or scratches on the surface of your connector. This will reduce the performance of your transmission system.

When spraying compressed air, hold the can upright. If the can is held at a slant, propellant could escape and dirty your optical device. First spray into the air, as the initial stream of compressed air could contain some condensation or propellant. Such condensation leaves behind a filmy deposit.

Please be friendly to your environment and use a CFC-free aerosol.

Additional Cleaning Equipment

Some Cleaning Procedures need the following equipment, which is not required to clean each instrument:

- Microscope with a magnification range about 50X up to 300X
- Ultrasonic bath
- Warm water and liquid soap
- Premoistened cleaning wipes
- Polymer film
- Infrared Sensor Card

Microscope with a magnification range about 50X up to 300X

A microscope can be found in most photography stores, or can be obtained through or specialist mail order companies. Special fiber-scopes are available from suppliers of splicing equipment.

Ideally, the light source on your microscope should be very flexible. This will allow you to examine your device closely and from different angles.

A microscope helps you to estimate the type and degree of dirt on your device. You can use a microscope to choose an appropriate cleaning method, and then to examine the results. You can also use your microscope to judge whether your optical device (such as a connector) is severely scratched and is, therefore, causing inaccurate measurements.

Ultrasonic bath

Ultrasonic baths are also available from photography or laboratory suppliers or specialist mail order companies.

An ultrasonic bath will gently remove fat and other stubborn dirt from your optical devices. This helps increase the life span of the optical devices.

Only use isopropyl alcohol in your ultrasonic bath, as other solvents may cause damage.

Warm water and liquid soap

Only use water if you are sure that there is no other way of cleaning your optical device without causing corrosion or damage. Do not use hot water, as this may cause mechanical stress, which can damage your optical device.

Ensure that your liquid soap has no abrasive properties or perfume in it. You should also avoid normal washing up liquid, as it can cover your device in an iridescent film after it has been air dried.

Some lenses and mirrors also have a special coating, which may be sensitive to mechanical stress, or to fat and liquids. For this reason we recommend you do not touch them.

If you are not sure how sensitive your device is to cleaning, please contact the manufacturer or your sales distributor.

Premoistened cleaning wipes

Use pre-moistened cleaning wipes as described in each individual cleaning procedure. Cleaning wipes may be used in every instance where a moistened soft tissue or cotton swab is applied.

Polymer film

Polymer film is available from laboratory suppliers or specialist mail order companies.

Using polymer film is a gentle method of cleaning extremely sensitive devices, such as reference reflectors and mirrors.

Infrared Sensor Card

Infrared sensor cards are available from laboratory suppliers or specialist mail order companies.

With the help of this card you are able to inspect the shape of laser light emitted. The invisible laser beam is projected onto the sensor card. The light beam's infrared wavelengths are reflected at visible wavelengths, so becoming visible to the normal eye as a round spot.

Take care never to look into the end of a fiber or any other optical component, when they are in use. This is because the laser can seriously damage your eyes.

Preserving Connectors

Listed below are some hints on how best to keep your connectors in the best possible condition.

Making Connections Before you make any connection you must ensure that all cables and connectors are clean. If they are dirty, use the appropriate cleaning procedure.

When inserting the ferrule of a patchcord into a connector or an adapter, make sure that the fiber end does not touch the outside of the mating connector or adapter. Otherwise you will rub the fiber end against an unsuitable surface, producing scratches and dirt deposits on the surface of your fiber.

Dust Caps and Shutter Caps Be careful when replacing dust caps after use. Do not press the bottom of the cap onto the fiber as any dust in the cap can scratch or dirty your fiber surface.

When you have finished cleaning, put the dust cap back on, or close the shutter cap if the equipment is not going to be used immediately.

Always keep the caps on the equipment when it is not in use.

All of Agilent Technologies' lightwave instruments and accessories are shipped with either laser shutter caps or dust caps. If you need additional or replacement dust caps, contact your nearest Agilent Technologies Sales/Service Office.

Immersion Oil and Other Index Matching Compounds Wherever possible, do not use immersion oil or other index matching compounds with your device. They are liable to impair and dirty the surface of the device. In addition, the characteristics of your device can be changed and your measurement results affected.

Cleaning Instrument Housings

Use a dry and very soft cotton tissue to clean the instrument housing and the keypad. Do not open the instruments as there is a danger of electric shock, or electrostatic discharge. Opening the instrument can cause damage to sensitive components, and in addition your warranty will be invalidated.

General Cleaning Procedure

- Light dirt** If you just want to clean away light dirt, observe the following procedure for all devices:
- Use compressed air to blow away large particles.
 - Clean the device with a dry cotton swab.
 - Use compressed air to blow away any remaining filament left by the swab.
- Heavy dirt** If the above procedure is not enough to clean your instrument, follow one of the procedures below.
- If you are unsure of how sensitive your device is to cleaning, please contact the manufacturer or your sales distributor

How to clean connectors

Cleaning connectors is difficult as the core diameter of a single mode fiber is only about 9 μm . This generally means you cannot see streaks or scratches on its surface. To be certain of the condition of the surface of your connector and to check it after cleaning, you need a microscope.

In the case of scratches, or of dust that has been burnt onto the surface of the connector, you may have no option but to polish the connector. This depends on the degree of dirtiness, or the depth of the scratches. This is a difficult procedure and should only be performed by a skilled person, and as a last resort as it wears out your connector.

WARNING

Never look into the end of an optical cable that is connected to an active source.

To assess the projection of the emitted light beam you can use an infrared sensor card. Hold the card approximately 5 cm from the output of the connector. The invisible emitted light is projected onto the card and becomes visible as a small circular spot.

Cleaning procedure for high-power single mode connections

Optical single mode connectors for high-power applications (optical power levels above 100 mW) require careful cleaning to prevent the power density of burning dust or dirt into the fiber causing permanent damage to the devices and/or connectors. If this happens, measurements become inaccurate and unrepeatable.

The "Preferred Procedure" on page 87 or the "Procedure for Stubborn Dirt" on page 87 must be strictly followed for each part of the optical connection (connector, connector interface, and physical connector interface).

Always make sure that the fiber end-faces are properly cleaned and unscratched before connection. The fiber end faces must be visually inspected using a microscope with a magnification of at least 400x. For recommended fiber inspection microscopes, please refer to personnel in Agilent's Service Team.

The connection should be made immediately after cleaning and inspection to prevent the connection (connector, connector interface, and physical connector interface) from becoming dusty or dirty again.

Preferred Procedure An Optical Connector Cleaner, which resembles a VCR cleaning tape, is a device that can be used to clean grease from the surface of a connector.

- 1** Blow away any surface dust with compressed air.
- 2** Press the button on the side of the Optical Connector Cleaner device to ensure that a fresh strip of tape is ready.
- 3** Position the connector interface on the tape.
- 4** Holding the connector interface against the tape, rotate the interface about 180 degrees, then slide it across the surface of the tape.

Alternative Procedure Use the following procedure if an Optical Connector Cleaner is not available.

- 1** Clean the connector by rubbing a new, dry cotton swab over the surface using a small circular movement.
- 2** Blow away any remaining lint with compressed air.

Procedure for Stubborn Dirt Use this procedure when there is greasy dirt on the connector:

- 1** Moisten a new cotton swab with isopropyl alcohol.
- 2** Clean the connector by rubbing the cotton swab over the surface using a small circular movement.
- 3** Take a new, dry soft tissue and remove the alcohol, dissolved sediment and dust, by rubbing gently over the surface using a small circular movement.
- 4** Blow away any remaining lint with compressed air.

An Alternative Procedure A better, more gentle, but more expensive cleaning procedure is to use an ultrasonic bath with isopropyl alcohol.

- 1** Hold the tip of the connector in the bath for at least three minutes.
- 2** Take a new, dry soft tissue and remove the alcohol, dissolved sediment and dust, by rubbing gently over the surface using a small circular movement.
- 3** Blow away any remaining lint with compressed air.

How to clean optical head adapters

CAUTION

Some adapters have an anti-reflection coating on the back to reduce back reflection. This coating is extremely sensitive to solvents and mechanical abrasion. Extra care is needed when cleaning these adapters.

When using optical head adapters, periodically inspect the optical head's front window. Dust and metal particles can be propelled through the adapter's pinhole while inserting the connector ferrule into the receptacle. These dirt particles collect on the head's front window, which can lead to incorrect results if not removed.

Preferred Procedure Use the following procedure on most occasions.

- 1 Clean the adapter by rubbing a new, dry cotton swab over the surface using a small circular movement.
- 2 Blow away any remaining lint with compressed air.

Procedure for Stubborn Dirt Use this procedure when there is greasy dirt on the adapter:

- 1 Moisten a new cotton swab with isopropyl alcohol.
- 2 Clean the adapter by rubbing the cotton swab over the surface using a small circular movement.
- 3 Take a new, dry soft tissue and remove the alcohol, dissolved sediment and dust, by rubbing gently over the surface using a small circular movement.
- 4 Blow away any remaining lint with compressed air.

How to clean connector interfaces

CAUTION

Be careful when using pipe cleaners, as the core and the bristles of the pipe cleaner are hard and can damage the interface.

Do not use pipe cleaners on optical head adapters, as the hard core of normal pipe cleaners can damage the bottom of an adapter.

Preferred Procedure Use the following procedure on most occasions.

- 1 Clean the interface, when no lens is connected, by pushing and pulling a new, dry pipe cleaner into the opening. Rotate the pipe cleaner slowly as you do this.
- 2 Blow away any remaining lint with compressed air.

Procedure for Stubborn Dirt Use this procedure when there is greasy dirt on the interface:

- 1 Moisten a new pipe cleaner with isopropyl alcohol.
- 2 Clean the interface by pushing and pulling the pipe cleaner into the opening. Rotate the pipe cleaner slowly as you do this.
- 3 Using a new, dry pipe cleaner, and a new, dry cotton swab remove the alcohol, any dissolved sediment and dust.
- 4 Blow away any remaining lint with compressed air.

How to clean bare fiber adapters

Bare fiber adapters are difficult to clean. Protect from dust unless they are in use.

CAUTION

Never use any kind of solvent when cleaning a bare fiber adapter as solvents can:

- Damage the foam inside some adapters.
- Deposit dissolved dirt in the groove, which can then dirty the surface of an inserted fiber.

Preferred Procedure

Use the following procedure on most occasions.

- 1 Blow away any dust or dirt with compressed air.

Procedure for Stubborn Dirt

Use this procedure when there is greasy dirt on the adapter:

- 1 Clean the adapter by pushing and pulling a new, dry pipe cleaner into the opening. Rotate the pipe cleaner slowly as you do this.

CAUTION

Be careful when using pipe cleaners, as the core and the bristles of the pipe cleaner are hard and can damage the adapter.

- 2 Clean the adapter by rubbing a new, dry cotton swab over the surface using a small circular movement.
- 3 Blow away any remaining lint with compressed air.

How to clean lenses and instruments with an optical glass plate

Some lenses have special coatings that are sensitive to solvents, grease, liquid and mechanical abrasion. Take extra care when cleaning lenses with these coatings. Some instruments, for example, Agilent's optical heads have an optical glass plate to protect the sensor.

CAUTION

Do not attempt to access the internal parts of an Agilent N3988A video microscope for cleaning or for any other purpose.

Lens assemblies consisting of several lenses are not normally sealed. Therefore, use as little alcohol as possible, as it can get between the lenses and in doing so can change the properties of projection.

If you are cleaning an Agilent 8162*A optical head, periodically inspect the optical head's front window for dust and other particles. Dust and particles can be propelled through the optical head adapter's pinhole while inserting a connector ferrule into the receptacle. Particles on the optical head's front window can significantly impair measurement results.

NOTE Do not dry the lens by rubbing with with cloth or other material, which may scratch the lens surface.

- Preferred Procedure Use the following procedure on most occasions.
- 1 Clean the lens by rubbing a new, dry cotton swab over the surface using a small circular movement.
 - 2 Blow away any remaining lint with compressed air.

- Procedure for Stubborn Dirt Use this procedure when there is greasy dirt on the lens:
- 1 Moisten a new cotton swab with isopropyl alcohol.
 - 2 Clean the lens by rubbing the cotton swab over the surface using a small circular movement.
 - 3 Using a new, dry cotton swab remove the alcohol, any dissolved sediment and dust.
 - 4 Blow away any remaining lint with compressed air.

How to clean instruments with a fixed connector interface

You should only clean instruments with a fixed connector interface when it is absolutely necessary. This is because it is difficult to remove any used alcohol or filaments from the input of the optical block.

It is important, therefore, to keep dust caps on the equipment at all times, except when your optical device is in use.

If you do discover filaments or particles, the only way to clean a fixed connector interface and the input of the optical block is to use compressed air.

If there are fluids or fat in the connector, please refer the instrument to the skilled personnel of Agilent's service team.

- NOTE Both the surface and the jacket of the attached connector should be completely dry and clean.

CAUTION

Only use clean, dry compressed air. Make sure that the air is free of dust, water, and oil. If the air that you use is not clean and dry, this can lead to filmy deposits or scratches on the surface of your connector interface. This will degrade the performance of your transmission system.

Never try to open the instrument and clean the optical block by yourself, because it is easy to scratch optical components, and cause them to become misaligned.

How to clean instruments with a physical contact interface

Remove any connector interfaces from the optical output of the instrument before you begin the cleaning procedure.

Cleaning interfaces is difficult as the core diameter of a single mode fiber is only about 9 μ m. This generally means you cannot see streaks or scratches on the surface. To be certain of the degree of pollution on the surface of your interface and to check whether it has been removed after cleaning, you need a microscope.

WARNING

Never look into an optical output, because this can seriously damage your eyesight.

To assess the projection of the emitted light beam you can use an infrared sensor card. Hold the card approximately 5 cm from the interface. The invisible emitted light is projected onto the card and becomes visible as a small circular spot.

Optical single mode connections for high-power applications (optical power levels above 100mW) require careful cleaning to prevent the power density of burning dust or dirt into the fiber causing permanent damage of the devices and/or connectors. If this happens, measurements become inaccurate and non-repeatable.

Preferred Procedure Use the following procedure on most occasions.

- 1 Clean the interface by rubbing a new, dry cotton swab over the surface using a small circular movement.
- 2 Blow away any remaining lint with compressed air.

Procedure for Stubborn Dirt Use this procedure when there is greasy dirt on the interface:

- 1 Moisten a new cotton swab with isopropyl alcohol.
- 2 Clean the interface by rubbing the cotton swab over the surface using a small circular movement.
- 3 Take a new, dry soft tissue and remove the alcohol, dissolved sediment and dust, by rubbing gently over the surface using a small circular movement.
- 4 Blow away any remaining lint with compressed air.

NOTE This procedures must be strictly followed for each part of the optical connection (connector, connector interface and physical connector interface).

NOTE The connection should be made immediately after cleaning and inspection to prevent the connection (connector, connector interface and physical connector interface) from getting dusty or dirty again.

NOTE Always make sure that the fiber end faces are properly cleaned and unscratched before connection. The fiber end faces must be visually inspected using a microscope with a magnification of at least 400x. For recommended fiber inspection microscopes, please refer to Agilent 's service team personnel.

How to clean instruments with a recessed lens interface

For instruments with a *deeply* recessed lens interface (for example the Agilent 81633A and 81634A Power Sensors) do NOT follow this procedure. Alcohol and compressed air could damage your lens even further.

Keep your dust and shutter caps on when your instrument is not in use. This should prevent it from getting too dirty.

If you must clean such instruments, please refer the instrument to the skilled personnel of Agilent's service team.

Preferred Procedure Use the following procedure on most occasions.

- 1** Blow away any dust or dirt with compressed air.
If this is not sufficient, then
 - a** Clean the interface by rubbing a new, dry cotton swab over the surface using a small circular movement.
 - b** Blow away any remaining lint with compressed air.

Procedure for Stubborn Dirt Use this procedure when there is greasy dirt on the interface, and using the preferred procedure is not sufficient.

Using isopropyl alcohol should be your last choice for recessed lens interfaces because of the difficulty of cleaning out any dirt that is washed to the edge of the interface.

- 1** Moisten a new cotton swab with isopropyl alcohol.
- 2** Clean the interface by rubbing the cotton swab over the surface using a small circular movement.
- 3** Take a new, dry soft tissue and remove the alcohol, dissolved sediment and dust, by rubbing gently over the surface using a small circular movement.
- 4** Blow away any remaining lint with compressed air.

How to clean optical devices which are sensitive to mechanical stress and pressure

Some optical devices, such as the Agilent 81000BR Reference Reflector, which has a gold plated surface, are very sensitive to mechanical stress or pressure. Do not use cotton swabs, soft tissues or other mechanical cleaning tools, as these can scratch or destroy the surface.

Preferred Procedure Use the following procedure on most occasions.

- 1** Blow away any dust or dirt with compressed air.

Procedure for Stubborn Dirt To clean devices that are extremely sensitive to mechanical stress or pressure you can also use an optical clean polymer film. This procedure is time-consuming, but you avoid scratching or destroying the surface.

- 1 Put the film on the surface and wait at least 30 minutes to make sure that the film has had enough time to dry.
- 2 Remove the film and any dirt with special adhesive tapes.

Alternative Procedure For these types of optical devices you can often use an ultrasonic bath with isopropyl alcohol. Only use the ultrasonic bath if you are sure that it won't cause any damage any part of the device.

- 1 Put the device into the bath for at least three minutes.
- 2 Blow away any remaining liquid with compressed air.

If there are any streaks or drying stains on the surface, repeat the cleaning procedure.

How to clean metal filters or attenuator gratings

This kind of device is extremely fragile. A misalignment of the grating leads to inaccurate measurements. Never touch the surface of the metal filter or attenuator grating.

Be very careful when using or cleaning these devices. Do not use cotton swabs or soft tissues, as there is the danger that you cannot remove the lint and that the device will be destroyed by becoming mechanically distorted.

Preferred Procedure Use the following procedure on most occasions.

- 1 Use compressed air at a distance and with low pressure to remove any dust or lint.

Procedure for Stubborn Dirt Do not use an ultrasonic bath as this can damage your device.

Use this procedure when there is greasy dirt on the device:

- 1 Put the optical device into a bath of isopropyl alcohol, and wait at least 10 minutes.
- 2 Remove the fluid using compressed air at some distance and with low pressure. If there are any streaks or drying stains on the surface, repeat the whole cleaning procedure.

Additional Cleaning Information

The following cleaning procedures may be used with other optical equipment:

- How to clean bare fiber ends
- How to clean large area lenses and mirrors

How to clean bare fiber ends

Bare fiber ends are often used for splices or, together with other optical components, to create a parallel beam.

The end of a fiber can often be scratched. You make a new cleave. To do this:

- 1** Strip off the cladding.
- 2** Take a new soft tissue and moisten it with isopropyl alcohol.
- 3** Carefully clean the bare fiber with this tissue.
- 4** Make your cleave and immediately insert the fiber into your bare fiber adapter in order to protect the surface from dirt.

Preferred Procedure There is an easy method for removing dust from bare fiber ends.

1. Touch the bare fiber end with adhesive tape. Any dust will be removed.

How to clean large area lenses and mirrors

Some mirrors, as those from a monochromator, are very soft and sensitive. Therefore, never touch them and do not use cleaning tools such as compressed air or polymer film.

Some lenses have special coatings that are sensitive to solvents, grease, liquid and mechanical abrasion. Take extra care when cleaning lenses with these coatings.

Lens assemblies consisting of several lenses are not normally sealed. Therefore, use as little liquid as possible, as it can get between the lenses and in doing so can change the properties of projection.

Preferred Procedure Use the following procedure on most occasions.

- 1** Blow away any dust or dirt with compressed air.

Procedure for Stubborn Dirt Use this procedure when there is greasy dirt on the lens:

CAUTION

Only use water if you are sure that there is no other way of cleaning your optical device without causing corrosion or damage. Do not use hot water, as this may cause mechanical stress, which can damage your optical device.

Ensure that your liquid soap has no abrasive properties or perfume in it. You should also avoid normal washing up liquid, as it can cover your device in an iridescent film after it has been air dried.

Some lenses and mirrors also have a special coating, which may be sensitive to mechanical stress, or to fat and liquids. For this reason we recommend you do not touch them.

If you are not sure how sensitive your device is to cleaning, please contact the manufacturer or your sales distributor.

- 1** Moisten the lens or the mirror with water.
- 2** Put a little liquid soap on the surface and gently spread the liquid over the whole area.
- 3** Wash off the emulsion with water, being careful to remove it all, as any remaining streaks can impair measurement accuracy.
- 4** Take a new, dry soft tissue and remove the water, by rubbing gently over the surface using a small circular movement.
- 5** Blow away remaining lint with compressed air.

Alternative Procedure A To clean lenses that are extremely sensitive to mechanical stress or pressure you can also use an optical clean polymer film. This procedure is time-consuming, but you avoid scratching or destroying the surface.

- 1** Put the film on the surface and wait at least 30 minutes to make sure that the film has had enough time to dry.
- 2** Remove the film and any dirt with special adhesive tapes.

Alternative Procedure B If your lens is sensitive to water then:

- 1** Moisten the lens or the mirror with isopropyl alcohol.
- 2** Take a new, dry soft tissue and remove the alcohol, dissolved sediment and dust, by rubbing gently over the surface using a small circular movement.
- 3** Blow away remaining lint with compressed air.

Other Cleaning Hints

Selecting the correct cleaning method is an important element in maintaining your equipment and saving you time and money. This chapter highlights the main cleaning methods, but cannot address every individual circumstance.

This section contains some additional hints which we hope will help you further. For further information, please contact your local Agilent Technologies representative.

- | | |
|--|---|
| Making the connection | <p>Before you make any connection you must ensure that all lightwave cables and connectors are clean. If not, then use the appropriate cleaning methods.</p> <p>When you insert the ferrule of a patchcord into a connector or an adapter, ensure that the fiber end does not touch the outside of the mating connector or adapter. Otherwise, the fiber end will rub up against something which could scratch it and leave deposits.</p> |
| Lens cleaning papers | <p>Some special lens cleaning papers are not suitable for cleaning optical devices like connectors, interfaces, lenses, mirrors and so on. To be absolutely certain that a cleaning paper is applicable, please ask the salesperson or the manufacturer.</p> |
| Immersion oil and other index matching compounds | <p>Do not use immersion oil or other index matching compounds with optical sensors equipped with recessed lenses. They are liable to dirty the detector and impair its performance. They may also alter the property of depiction of your optical device, thus rendering your measurements inaccurate.</p> |
| Cleaning the housing and the mainframe | <p>When cleaning either the mainframe or the housing of your instrument, only use a dry and very soft cotton tissue on the surfaces and the numeric pad.</p> <p>Never open the instruments as they can be damaged. Opening the instruments puts you in danger of receiving an electrical shock from your device, and renders your warranty void.</p> |

Index

A

Attenuator 7

C

Cleaning 63

- Additional equipment 69
- Connector Interfaces 74
- General Procedure 72
- High-power single mode connectors 72
- How to clean connectors 72
- Importance of 66
- Materials required 66
- Preserving Connectors 71
- Safety Precautions 65

Connectors

- How to clean 72
- Preserving 71

Conventions 7

D

Definition of Terms 23

- Attenuation 24
- Attenuation flatness 24
- Attenuation range 25
- Attenuation setting mode 25
- Attenuation uncertainty 25
- Constant operating conditions 25
- Insertion Loss 26
- Insertion loss flatness 26
- Maximum Input Power 26
- Operating temperature 27
- Operation Temperature 27
- Polarization Dependent Loss (PDL) 27
- Polarization Extinction Ratio (PER) 27
- Power setting mode 27
- Power setting 27
- Relative power meter uncertainty 27
- Repeatability 28
- Resolution 28
- Return Loss 28
- Settling Time 29
- Shutter Isolation 29
- Total Loss 30
- Transition speed 30
- Wavelength range 30

F

Firmware

- Prerequisites 4
- Revision Checking 6

Front Panel

- Agilent 81570A 8
- Agilent 81571A 8
- Agilent 81576A 10

Agilent 81577A 10
Agilent 81578A 9
Controls and Indicators 11

G

Getting Started 5

I

Inspection 3

L

Line Power 4

M

Mueller method 48

O

Optical Output 13
Angled & Straight Contact Connectors 13

Optional features 17

P

Performance Test
Procedure 38
Required Test Equipment 36

Performance Tests 35

S

Safety

Cleaning 65
Symbols 3
Warnings & Cautions 3, 4

Specifications 31

Variable optical attenuator modules for multimode applications 34
Variable optical attenuator modules for single mode applications 32
Variable optical attenuator modules with power control for single mode applications 33

Storage & Shipment 4

U

Use Models 11

User's Guides 18

W

Wavelength flatness test 43

www.agilent.com

© Agilent Technologies GmbH 2005

Printed in Germany September 2005
Eight edition, September 2005



81570-90A01

